

w w . t u n g a l o y . c o m

New PVD grade for
general purpose is added
in multi-functional series





TUNGALLOY **TUNG**CUT

Multi-functional tool system for diverse grooving applications!

New grade AH7025 with excellent stability is added!

TUNG CUT

TUNGALOY

Multi-functional tool reduces tool cost and shortens set-up time.

Various insert grades are applicable for a wide range of applications.



● Multi-functional grooving system

Suitable for diverse grooving operations

External grooving, turning, and parting

CTER/L

- Screw clamp
- $W = 2 \text{ mm} - 8 \text{ mm}$
- $ar = 8 \text{ mm} - 36 \text{ mm}$
- Shank size: 16 - 32 mm

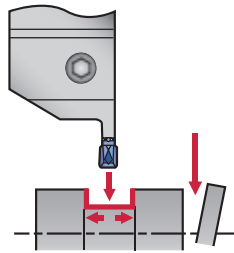

CAER/L

- Blade type
- Screw clamp
- $W = 3 \text{ mm} - 6 \text{ mm}$
- $ar = 16 \text{ mm} - 20 \text{ mm}$
- Shank size: 20 - 32 mm

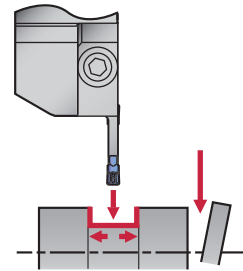

JCTER/L

- Screw clamp
- $W = 1.4 \text{ mm} - 3 \text{ mm}$
- $ar = 10 \text{ mm} - 16 \text{ mm}$
- Shank size: 10 - 20 mm
- For small auto lathe

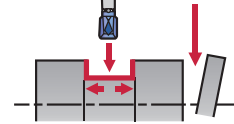

CGER/L

- Self clamp
- $W = 1.4 \text{ mm} - 3 \text{ mm}$
- $ar = 10 \text{ mm} - 16 \text{ mm}$
- Shank size: 10 mm - 20 mm
- For small auto lathe

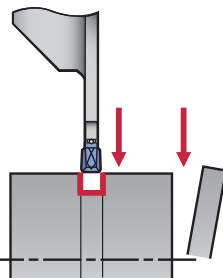

CGP

- Self clamp
- $W = 1.4 \text{ mm} - 8 \text{ mm}$
- Max parting dia: $\phi 120 \text{ mm}$
- Shank size: 20 mm - 25 mm

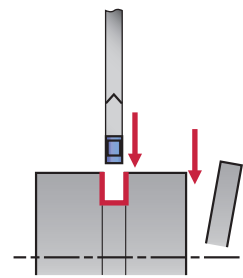

External and internal undercutting

CGEUR/L

- Screw clamp
- $W = 3 \text{ mm} - 6 \text{ mm}$
- $ar = 2.8 \text{ mm} - 3.4 \text{ mm}$
- Shank size: 16 mm - 25 mm

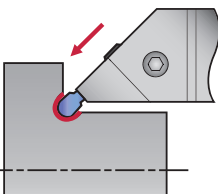

CGIUR/L

- Screw clamp
- $W = 3 \text{ mm} - 6 \text{ mm}$
- $ar = 2.8 \text{ mm}$
- Shank size: $\phi 20 \text{ mm} - \phi 25 \text{ mm}$

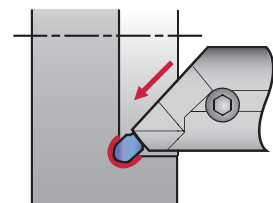

External and face grooving, and turning

CTEFR/L

- Screw clamp
- $W = 2 \text{ mm} - 6 \text{ mm}$
- $ar = 4.8 \text{ mm}$
- Shank size:
20 mm - 25 mm

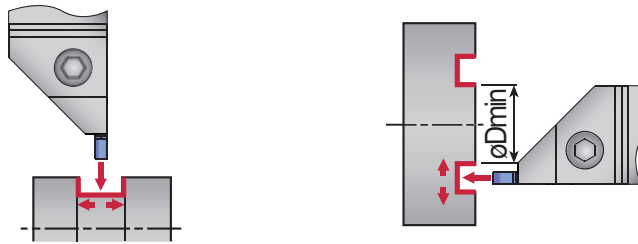

Face grooving and turning

CTFR/L

- Screw clamp
- $W = 3 \text{ mm} - 6 \text{ mm}$
- $ar = 10 \text{ mm} - 25 \text{ mm}$
- Shank size: 25 mm

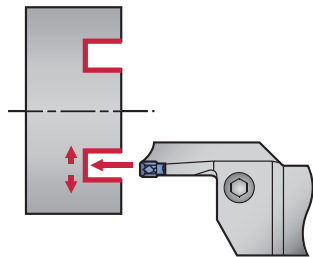

CAFR/L

- Blade type
- Screw clamp
- $W = 3 \text{ mm} - 6 \text{ mm}$
- $ar = 12 \text{ mm} - 25 \text{ mm}$
- Shank size:
20 mm - 32 mm

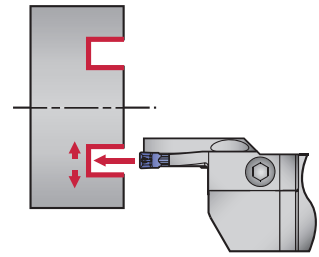

CTFVR/L

- Screw clamp
- $W = 3 \text{ mm} - 6 \text{ mm}$
- $ar = 10 \text{ mm} - 20 \text{ mm}$
- Shank size: 25 mm

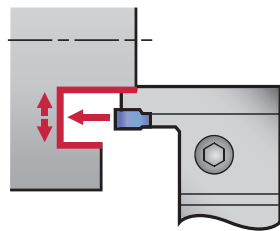

Face grooving, internal face grooving and turning

CTIFR/L

- Screw clamp
- $W = 3 \text{ mm} - 6 \text{ mm}$
- $ar = 5.5 \text{ mm}$
- Shank size:
 $\varnothing 25 \text{ mm} - \varnothing 32 \text{ mm}$

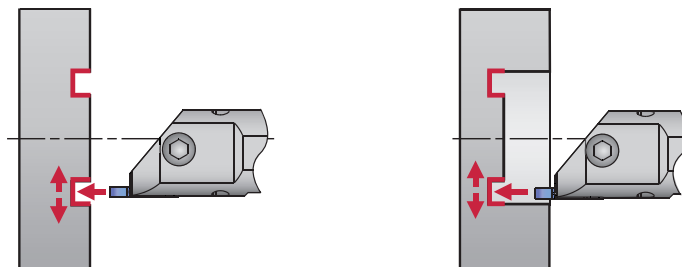

Internal face grooving and turning

CTIR/L

- Screw clamp
- $W = 2 \text{ mm} - 8 \text{ mm}$
- $ar = 4 \text{ mm} - 10 \text{ mm}$
- $\varnothing D_m = \varnothing 25 \text{ mm}$
- Shank size:
 $\varnothing 16 \text{ mm} - \varnothing 40 \text{ mm}$

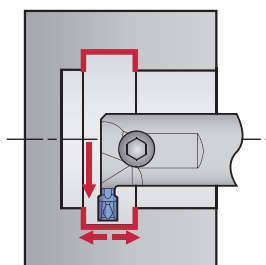

Cutting performance

New AH7025 grade - Drastically improved reliability with world's first technology

Tool life comparison in grooving

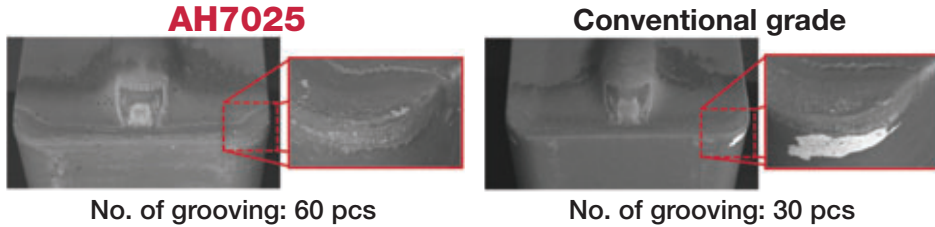

No. of grooving: 60 pcs

No. of grooving: 30 pcs

Alloy steel
(SCM440 / 42CrMo4)



Insert : DTE3-040 AH7025
Cutting speed : $V_c = 150$ m/min
Feed : $f = 0.17$ mm/rev
Groove depth : 17 mm
Machining : External grooving
Coolant : Wet

New AH7025 grade allows stable machining without peeling off, even in twice longer cutting time than conventional grade.

→ **The combination of Nano-multi-layered AlTiN Coating with high Al content and tough substrate provides highly efficient machining in various grooving operations.**

Unique chipbreaker provides excellent chip formation under various conditions.

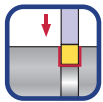

Grooving and parting

Carbon steel
(S45C / C45)

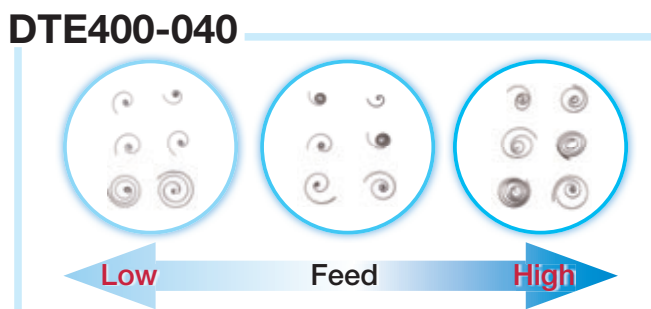
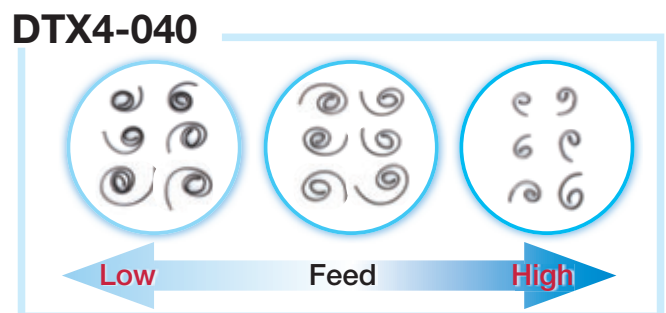
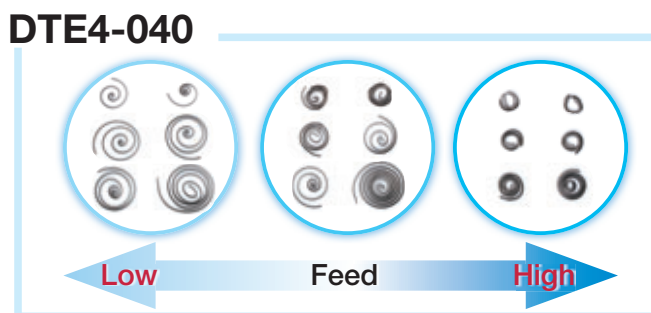
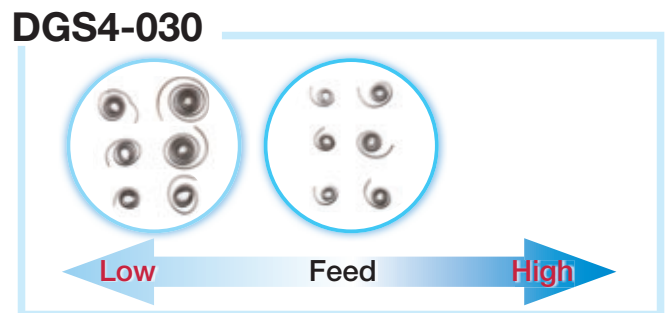
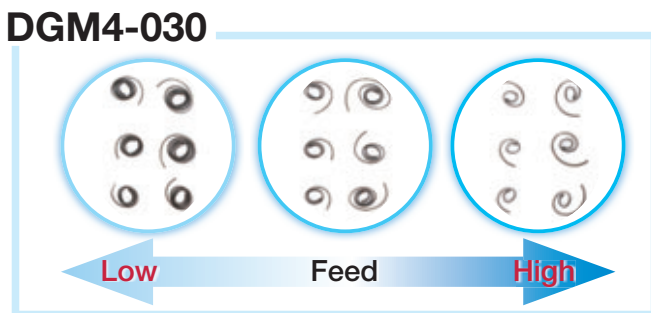

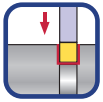

Grooving and parting

Stainless steel
(SUS304 / X5CrNi18-9)



DGM4-030

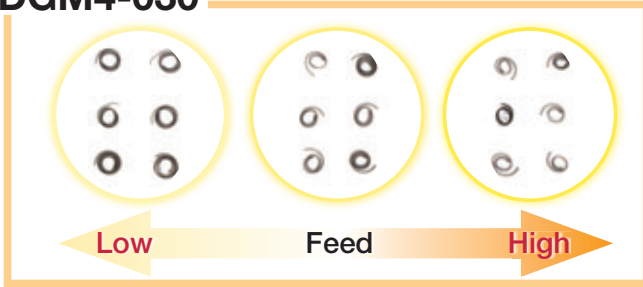

DGS4-030

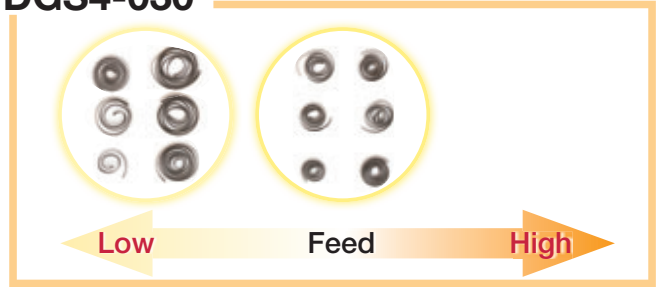

DTE4-040

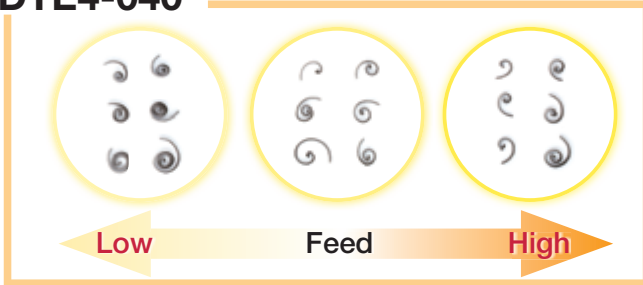

DTX4-040

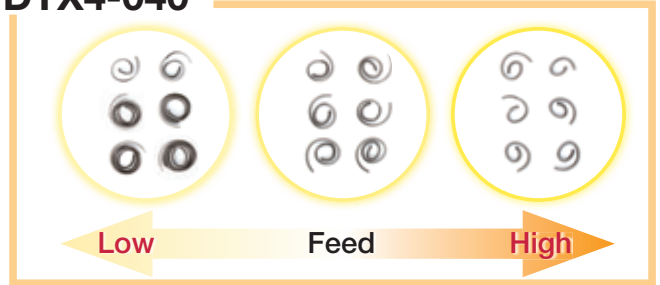

DTE400-040

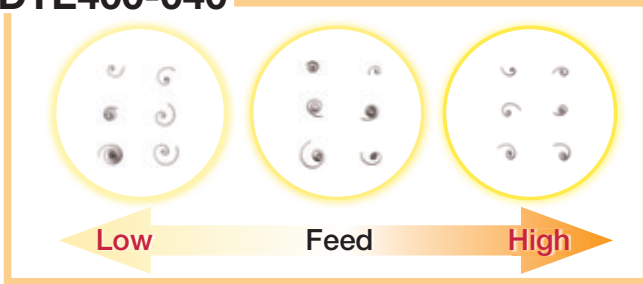

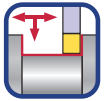

Grooving, parting, and turning

DTE

Good chip evacuation in turning at high feed due to the wide distance between the cutting edge and the chip former.



DTX

- Good cutting performance in grooving.
- Excellent chip formation in turning at low feed as the distance between the cutting edge and the chip former is small.

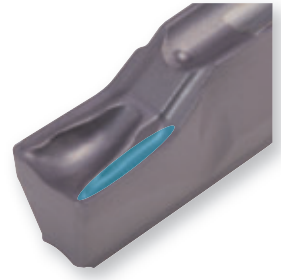

P Carbon steel (S45C / C45)

M Stainless steel (SUS304 / X5CrNi18-9)

DTE4-040

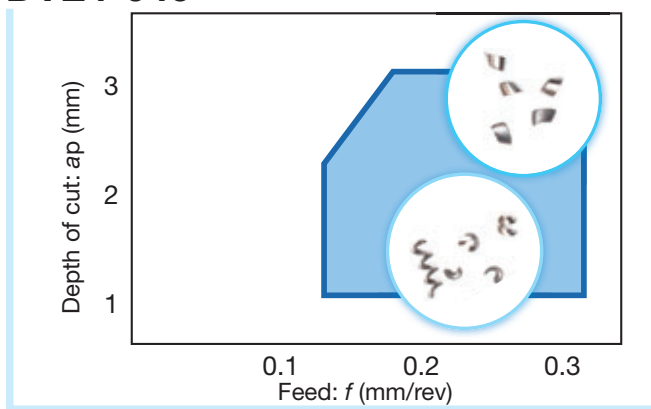

DTE4-040

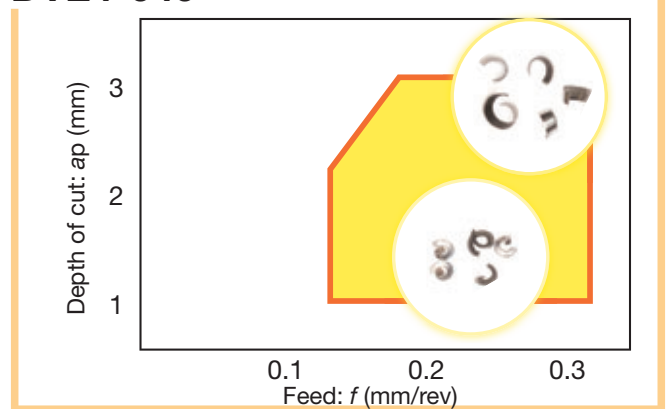

DTE400-040

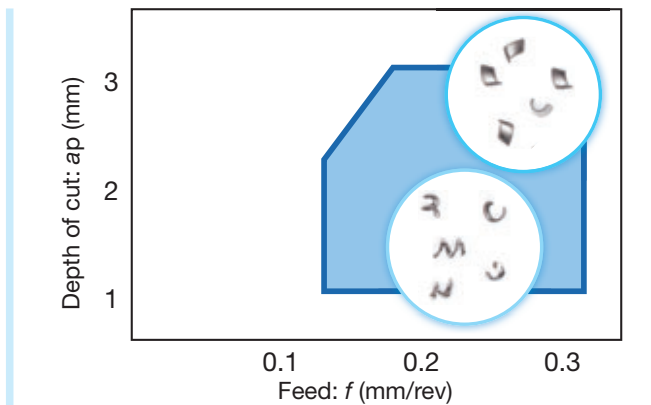

DTE400-040

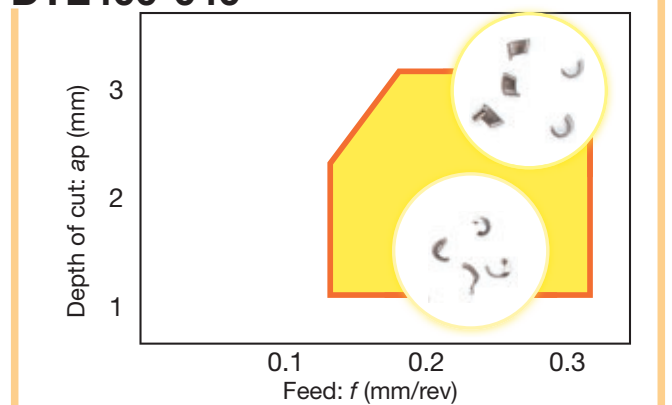

DTX4-040

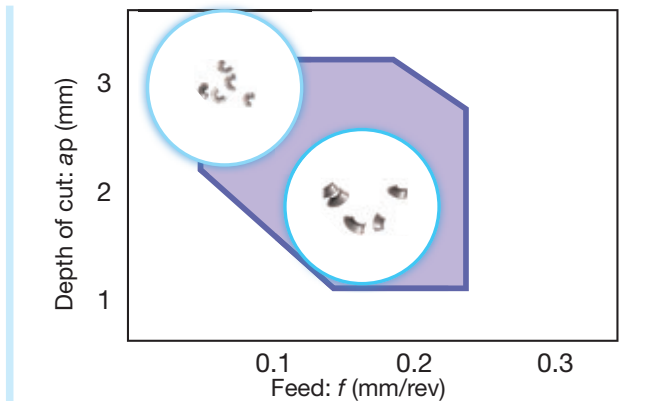

DTX4-040

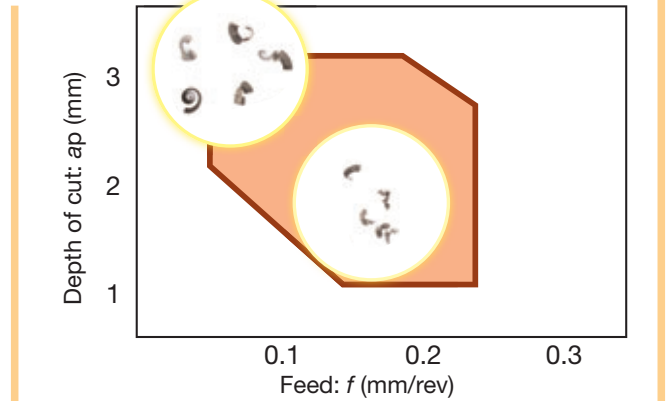

Grades

NEW AH7025

P M
S

- First recommended grade for general purpose
- New PVD coating with high Al content provides excellent adhesion strength
- Improved wear and chipping resistance

AH725

P M
S

- Recommended for general purpose machining
- Newly developed coating with well controlled crystal structure and fracture resistance
- Improved adhesion strength

T9125

P

- Suitable for steel machining at high speed
- New CVD coating and substrate deliver an outstanding balance of wear and chipping resistance

NS9530

P

- Advanced cermet for finish cutting of steel
- Innovative grade with incredible fracture and high wear resistance

GH130

P M
K

- Recommended for interrupted machining
- TiCNO PVD coating layer with high wear resistance
- High hardness and wear resistance

AH905

S

- Remarkable for machining of heat resistant alloy
- Exclusive coating layer improves adhesion strength and wear resistance

TH10

N

- Recommended for non-ferrous materials

BX360

H

- Suitable for hardened steel machining
- Ideal balance of wear and chipping resistance due to the optimum CBN content and grain size





KS05F

N S

- Recommended for non-ferrous materials and titanium

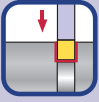
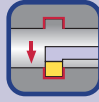
Grade	Substrate		Coating layer		Features
	Specific gravity	Hardness	Main Composition	Thickness (µm)	
NEW AH7025	14.4	91.3 HRA	(Al,Ti)N	3.5	First recommended grade with excellent wear resistance and toughness, that is suitable for machining of a wide range of materials.
AH725	14.4	91.5 HRA	(Ti,Al)N	2	PVD coated "Flash-coating" fine grain cemented carbide
T9125	13.7	90.0 HRA	TiCN + Al ₂ O ₃	16	This versatile grade dramatically improves chipping resistance
NS9530	6.8	91.7 HRA	-	-	Versatile cermet grade with incredible fracture and wear resistance
GH130	14.1	89.5 HRA	TiCNO	3	Superior resistance to chipping and fracture Excels in interrupted cutting
AH905	15.0	93.0 HRA	(Al,Ti)N	1.5	Excels in both cutting edge sharpness and wear resistance
TH10	14.7	92.0 HRA	-	-	Carbide grade with excellent wear resistance and toughness
KS05F	15.0	93.0 HRA	-	-	Carbide grade with excellent wear, fracture, and chip-welding resistances
BX360	-	3200 - 3400 Hv	-	-	CBN grade with exceptional balance of wear and chipping resistance

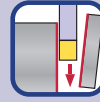
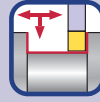
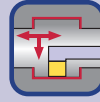
● Insert application

Insert	Application						
	Grooving			Parting	Turning		
	External	Internal	Face		External	Internal	Face
							
DGM / SGM	●		●	●			
DGS / SGS	●		●	●			
DTE	●		●		●		●
DGG	●		●				
DGE	●						
DTX	●	●	●	●	●	●	●
DTI		●				●	
DGIM / DGIS		●					
DTF			●				●
DTR	●		●		●		●
DTIU	● Undercutting	● Undercutting					
DTA					● AI wheel machining	● AI wheel machining	
SGN	●						

● Standard cutting conditions

ISO	Workpiece materials	Hardness	Priority	Grade	Cutting speed Vc (m/min)
P	Steels (S45C / C45, SCM435 / 34CrMo4 etc.)	< 300 HB	First choice	AH7025, AH725	50 - 180
		< 300 HB	Priority for wear resistance	T9125	80 - 200
		< 300 HB	Priority for impact resistance	GH130	50 - 120
		< 300 HB	Priority for surface finish	NS9530	80 - 220
M	Stainless steels (SUS303 / X10CrNiS18-9 etc.)	< 200 HB	First choice	AH7025, AH725	50 - 120
		< 200 HB	Priority for impact resistance	GH130	50 - 120
K	Grey cast irons (FC250 / GG25 / 250 etc.)	-	First choice	GH130	50 - 180
	Ductile cast irons (FCD450 / GGG45 / 450-10S etc.)	-	First choice	GH130	50 - 120
N	Aluminium alloys (Si < 12%)	-	First choice	TH10	100 - 500
S	Titanium alloys (Ti-6Al-4V etc.)	< HRC 40	First choice	AH905	20 - 80
		< HRC 40	Priority for impact resistance	AH7025, AH725	20 - 80
H	Hardened steels (SCM435 / 34CrMo4)	> HRC 50	First choice	BX360	80 - 150

● Features of inserts

External grooving and parting

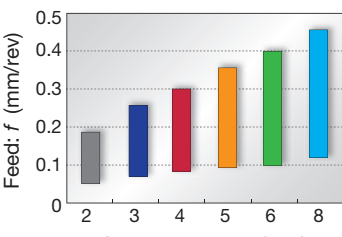
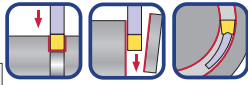

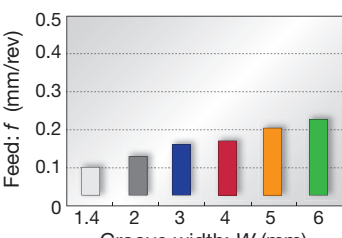
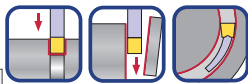
<p>DGM type (2 corners) SGM type (1 corner)</p> 	<p>1st choice for external grooving and parting off</p> <ul style="list-style-type: none"> ● Smooth chip evacuation ● Well-designed edge with high strength ● Handed insert available 	<p>■ Standard feed</p>  
---	---	---

<p>DGS type (2 corners) SGS type (1 corner)</p> 	<p>Lower cutting force and superior sharpness</p> <ul style="list-style-type: none"> ● Unique-designed edge and chipbreaker ● Handed insert available 	<p>■ Standard feed</p>  
---	--	---

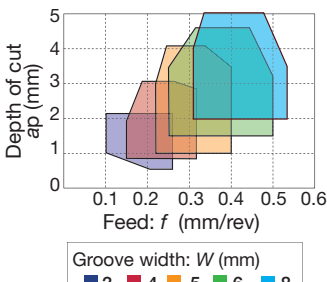
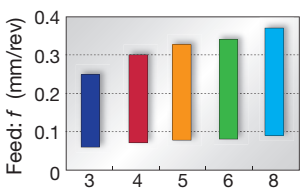
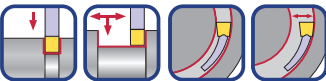
External and face grooving, and turning

<p>DTE type (2 corners)</p> 	<p>For general purpose</p> <ul style="list-style-type: none"> ● Unique chipbreaker makes chips shorter ● Molded and ground insert available 	<p>■ Standard feed and DoC</p>  <p>■ Standard feed</p>  
--	--	---

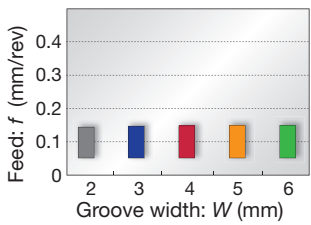
External and face grooving

<p>DGG type (2 corners)</p> 	<p>For non-ferrous materials and titanium</p> <ul style="list-style-type: none"> ● Chipbreaker with low cutting force ● Sharp cutting edge that prevents vibration and delivers fine surface finish 	<p>■ Standard feed</p>  
--	--	---

External, internal and face grooving, and turning

DTX type (2 corners)



Multi-functional type

- Well balanced sharpness and strength
- Multi functional insert

Standard feed and DoC

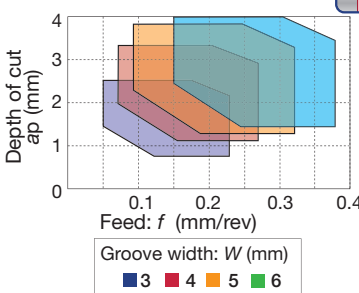

Standard feed

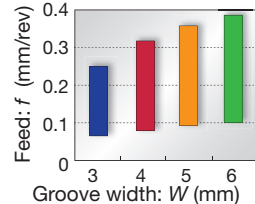

External grooving

DGE type (2 corners)



For high accurate and shallow groove

- Excellent chip control

Standard feed

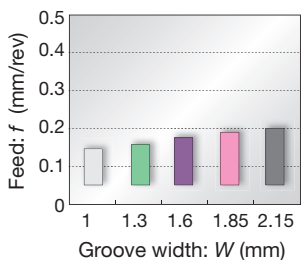

Profiling and undercutting

DTR type (2 corners)

Molded



Ground



Full radius type

- Excellent chip control
- Molded and ground insert available

Standard feed and DoC

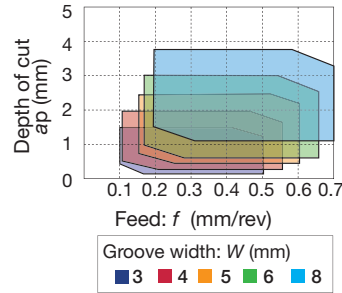

DTIU type (2 corners)



Full radius type

- Excellent chip control
- For undercutting

Standard feed and DoC

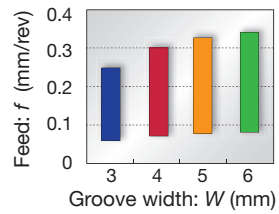

Internal grooving and turning

DTI type (2 corners)



1st choice for internal grooving

- Unique chipbreaker makes chips shorter
- Molded and ground insert available

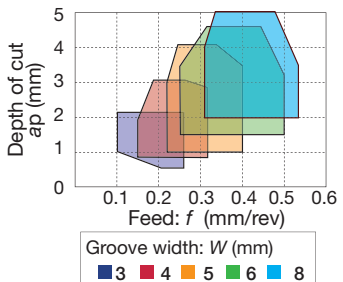

Standard feed and DoC



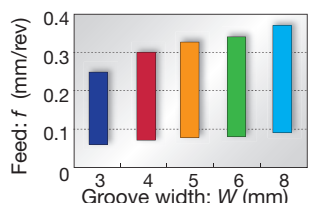

Standard feed

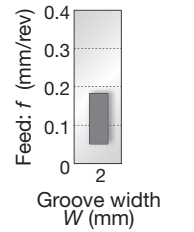

Small diameter internal grooving

<p>DGIM type (2 corners)</p> 	<p>2 mm insert width only (For general purpose) ■ Standard feed</p> <ul style="list-style-type: none"> ● Unique chipbreaker for excellent chip control ● Excellent fracture resistance due to optimum land on the cutting edge ● For general applications on steels & stainless steels 	
---	--	---



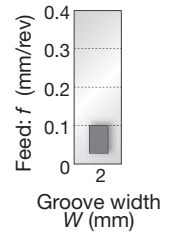

<p>DGIS type (2 corners)</p> 	<p>2 mm insert width only (Lower cutting force) ■ Standard feed</p> <ul style="list-style-type: none"> ● Low cutting force due to a unique land geometry ● Applicable for low carbon steels & stainless steels 	
---	---	---



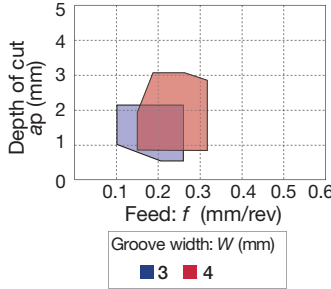
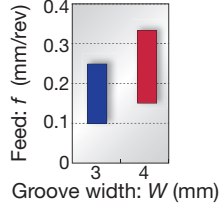

Face grooving and turning

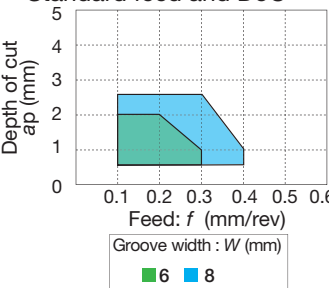
<p>DTF type (2 corners)</p> 	<p>1st choice for face grooving</p> <ul style="list-style-type: none"> ● Unique chipbreaker makes chips shorter ● Handed insert 	<p>■ Standard feed and DoC</p> 	<p>■ Standard feed</p> 
--	--	--	--

Aluminium wheel machining

<p>DTA type (2 corners)</p> 	<p>Full radius type</p> <ul style="list-style-type: none"> ● Excellent chip control ● For aluminium wheel profiling ● Ground insert 	<p>■ Standard feed and DoC</p> 	
--	---	---	---

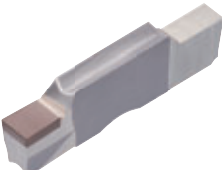
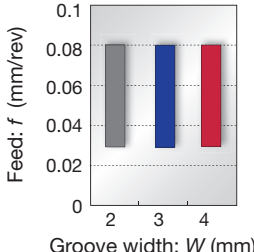
External grooving of hardened steels

<p>SGN-CBN type (1 corner)</p> 	<p>For hardened steel cutting</p> <ul style="list-style-type: none"> ● Optimum cutting edge shape for grooving of hardened steels ● High tolerance width for finishing ($W = \pm 0.025$ mm) 	<p>■ Standard feed</p> 	
---	---	---	---

Inserts

Notation of "insert seat size"

Seat size and grooving width are different. The seat size measurement is for the specification of the setting insert. Please note this point.

DGM External grooving and parting off, 2 corner

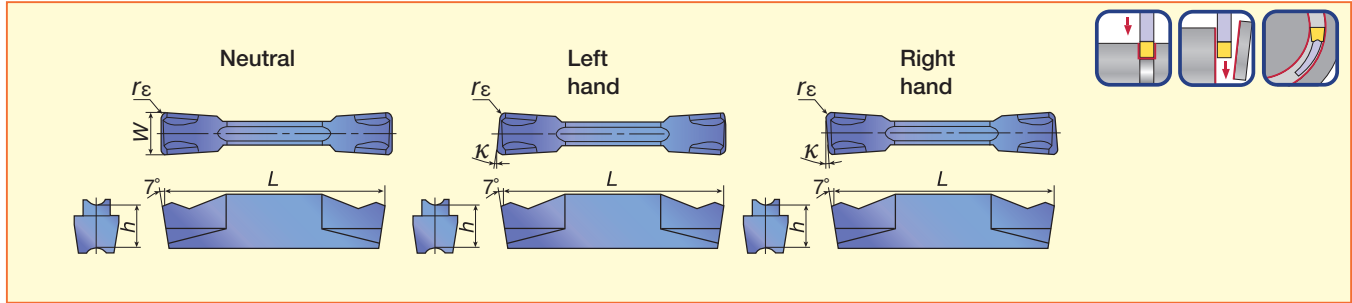

Insert seat size	Cat. No.	Grades										Dimensions (mm)						
		Coated															Cermet	
		T9125		NEW AH7025		AH725		AH905		GH130		NS9530		W±0.05	r _E	L	h	κ
		R	L	R	L	R	L	R	L	R	L	R	L					
2	DGM2-020	●		●		●				●		●		2	0.2	20	5	-
2	DGM2-020-6R/L					●	●			●	●			2	0.2	19.8	5	6°
2	DGM2-020-8R/L					●	●			●	●			2	0.2	19.8	5	8°
2	DGM2-020-15R/L					●	●			●	●			2	0.2	19.8	5	15°
2	DGM2-002-15R/L					●	●			●	●			2	0.02	19.35	5	15°
3	DGM3-020	●		●		●		●		●		●		3	0.2	20	5	-
3	DGM3-020-6R/L					●	●			●	●			3	0.2	19.9	5	6°
3	DGM3-002-6R/L					●	●			●	●			3	0.02	19.45	5	6°
3	DGM3-020-15R/L					●	●			●	●			3	0.2	19.9	5	15°
4	DGM4-030	●		●		●		●		●		●		4	0.3	20	5	-
4	DGM4-030-4R/L					●	●			●	●			4	0.3	19.8	5	4°
4	DGM4-030-15R/L					●	●			●	●			4	0.3	19.8	5	15°
5	DGM5-030	●		●		●		●		●		●		5	0.3	25	5.5	-
5	DGM5-030-4R					●	●			●	●			5	0.3	24.9	5.5	4°
6	DGM6-030	●		●		●		●		●		●		6	0.3	25	5.5	-
8	DGM8-040	●		●		●		●		●		●		8	0.4	30	6.7	-

SGM External deep grooving and parting off, 1 corner

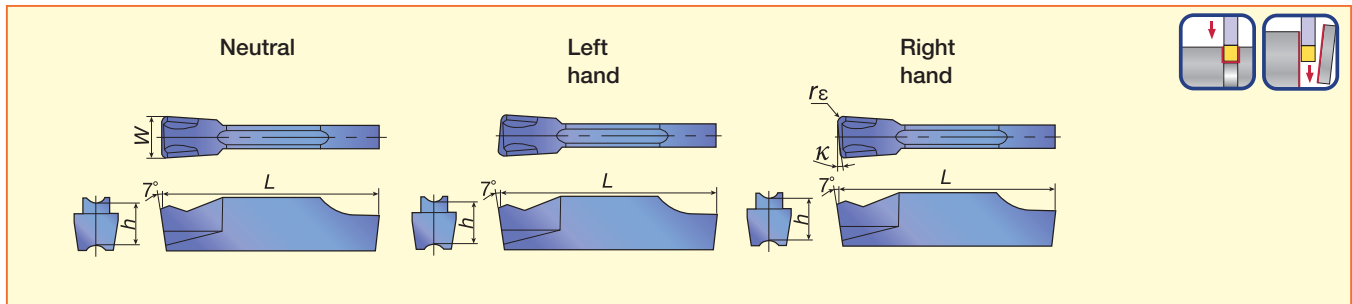

Insert seat size	Cat. No.	Grades				Dimensions (mm)				
		Coated								
		AH725		GH130		W±0.05	r _E	L	h	κ
		R	L	R	L					
2	SGM2-020		●		●	2	0.2	20	5	-
2	SGM2-020-6R/L	●		●		2	0.2	19.8	5	6°
3	SGM3-020		●		●	3	0.2	20	5	-
3	SGM3-020-6R/L	●		●		3	0.2	19.6	5	6°
3	SGM3-020-15R/L	●		●		3	0.2	19.6	5	15°
4	SGM4-030		●		●	4	0.3	20	5	-
4	SGM4-030-4R/L	●		●		4	0.3	19.65	5	4°
5	SGM5-030		●		●	5	0.3	25	5.5	-
6	SGM6-030		●		●	6	0.3	25	5.5	-

● : Stocked items

DGS

External grooving and parting off, 2 corner

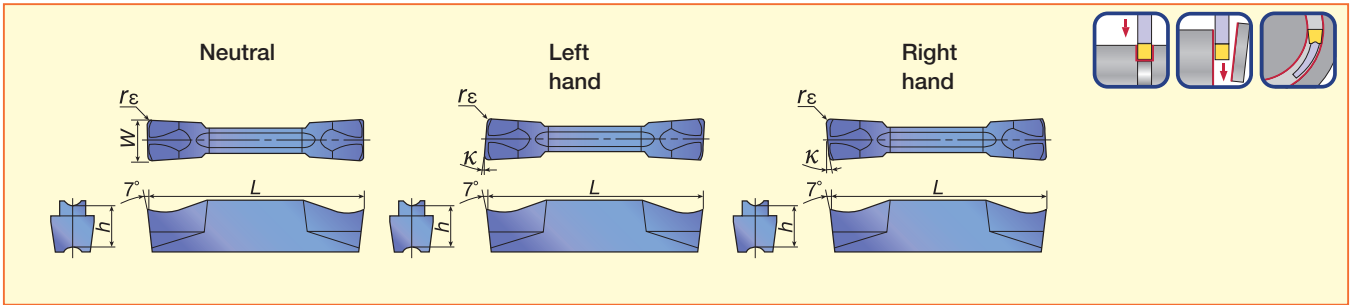

Insert seat size	Cat. No.	Grades										Dimensions (mm)					
		Coated								Cermet		$W_{\pm 0.05}$	r_{ϵ}	L	h	κ	
		T9125		NEW AH7025		AH725		GH130		NS9530							
R	L	R	L	R	L	R	L	R	L	R	L						
1	DGS1.4-016					●		●					1.4	0.16	16	4.3	-
2	DGS2-020	●		●		●		●		●			2	0.2	20	5	-
2	DGS2-020-6R/L					●	●	●	●				2	0.2	19.95	5	6°
2	DGS2-002-6R/L					●	●	●	●				2	0.02	19.8	5	6°
2	DGS2-020-15R/L					●	●	●	●				2	0.2	19.95	5	15°
2	DGS2-002-15R/L					●	●	●	●				2	0.02	19.8	5	15°
3	DGS3-020	●		●		●		●		●			3	0.2	20	5	-
3	DGS3-020-6R/L					●	●	●	●				3	0.2	19.9	5	6°
3	DGS3-002-6R/L					●	●	●	●				3	0.02	19.6	5	6°
3	DGS3-020-15R/L					●	●	●	●				3	0.2	19.9	5	15°
3	DGS3-002-15R/L					●	●	●	●				3	0.02	19.45	5	15°
4	DGS4-030	●		●		●		●		●			4	0.3	20	5	-
4	DGS4-030-4R/L					●	●	●	●				4	0.3	19.8	5	4°
5	DGS5-030	●				●		●		●			5	0.3	25	5.5	-
6	DGS6-030	●				●		●					6	0.3	25	5.5	-

Caution

Cat. No.	ϕD_{max} (mm)	Cat. No.	ϕD_{max} (mm)
DGM2-002-15R/L	28	DGS2-002-15R/L	28
DGM3-002-15R/L	29	DGS3-002-15R/L	29
DGM4-030-15R/L	30	SGS3-020-15R/L	103
SGM3-020-15R/L	103	SGS3-002-15R/L	34

The tool will interfere with the workpiece when grooving larger diameter than ϕD_{max} .

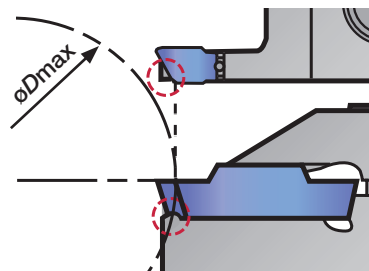

SGS

External deep grooving and parting off, 1 corner

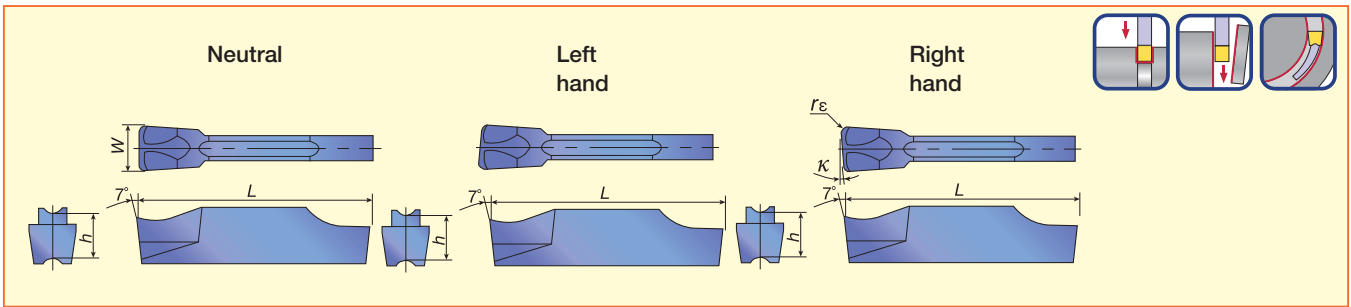

Insert seat size	Cat. No.	Grades				Dimensions (mm)				
		Coated				W±0.05	r _ε	L	h	κ
		AH725		GH130						
R	L	R	L							
2	SGS2-020	●		●		2	0.2	20	5	-
2	SGS2-020-6R/L	●	●	●	●	2	0.2	19.8	5	6°
2	SGS2-020-15R/L	●	●	●	●	2	0.2	19.8	5	15°
3	SGS3-020	●		●		3	0.2	20	5	-
3	SGS3-020-6R/L	●	●	●	●	3	0.2	19.64	5	6°
3	SGS3-002-6R/L	●	●	●	●	3	0.02	19.8	5	6°
3	SGS3-020-15R/L	●	●	●	●	3	0.2	19.64	5	15°
3	SGS3-002-15R/L	●	●	●	●	3	0.02	19.8	5	15°
4	SGS4-030	●		●		4	0.3	20	5	-
5	SGS5-030	●		●		5	0.3	25	5.5	-
6	SGS6-030	●		●		6	0.3	25	5.5	-

DGE

External grooving

Ground

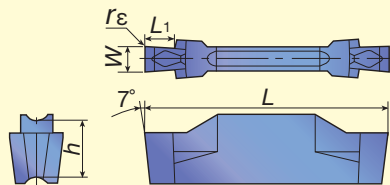

Insert seat size	Cat. No.	Grades			Dimensions (mm)				
		Coated		Cermet	W±0.02	r _ε ±0.05	L ₁	L	h
		AH725	GH130	NS9530					
2	DGE100-000	●	●	●	1.00	0.00	2.5	20	5
2	DGE130-000	●	●	●	1.30	0.00	2.5	20	5
2	DGE160-010	●	●	●	1.60	0.10	2.5	20	5
2	DGE185-010	●	●	●	1.85	0.10	3.5	20	5
2	DGE215-015	●	●	●	2.15	0.15	3.5	20	5

Caution

øD_{max} is limited as shown in the picture to the right according to the groove depth, G.D. Please refer to the following table.

G.D = Groove depth

Cat. No.	Max. groove depth (mm)	øD _{max} (mm)				
		G.D. = 1	G.D. = 1.5	G.D. = 2	G.D. = 2.5	G.D. = 3
DGE100-000	2	∞	18.6	11.5	-	-
DGE130-000						
DGE160-010						
DGE185-010	3				8.8	7
DGE215-015						

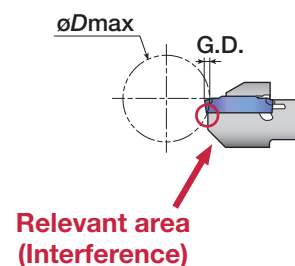

● : Stocked items

DTE

External, face grooving and turning

Ground

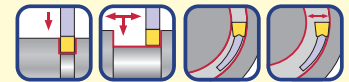
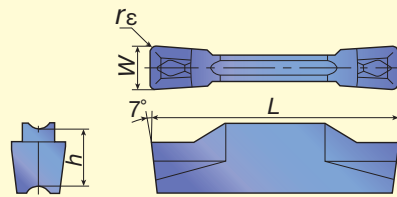

Insert seat size	Cat. No.	Grades					Dimensions (mm)			
		Coated				Cermet	$W \pm 0.02$	$r_{\epsilon} \pm 0.05$	L	h
		T9125	NEW AH7025	AH725	GH130					
3	DTE265-015	●	●	●	●	●	2.65	0.15	20	5
3	DTE300-020	●	●	●	●	●	3	0.2	20	5
3	DTE300-040	●		●	●	●	3	0.4	20	5
3	DTE315-015	●		●	●	●	3.15	0.15	20	5
4	DTE400-040	●		●	●	●	4	0.4	20	5
4	DTE400-080	●	●	●	●	●	4	0.8	20	5
4	DTE415-015	●		●	●	●	4.15	0.15	20	5
5	DTE478-055	●		●	●	●	4.78	0.55	25	5.5
5	DTE500-040	●		●	●	●	5	0.4	25	5.5
5	DTE500-080	●	●	●	●	●	5	0.8	25	5.5
5	DTE515-015	●		●	●		5.15	0.15	25	5.5
6	DTE600-080	●	●	●	●		6	0.8	25	5.5
6	DTE600-120	●		●	●		6	1.2	25	5.5
8	DTE800-080	●		●	●		8	0.8	30	6.7
8	DTE800-120	●		●	●		8	1.2	30	6.7

DTE

External, face grooving and turning

Molded

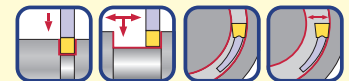
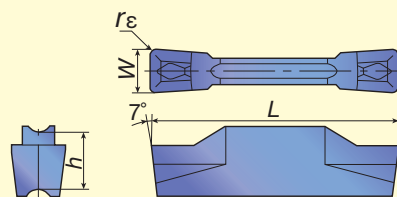

Insert seat size	Cat. No.	Grades					Dimensions (mm)			
		Coated				Cermet	$W \pm 0.02$	$r_{\epsilon} \pm 0.05$	L	h
		T9125	NEW AH7025	AH725	GH130					
3	DTE3-040	●	●	●	●	●	3	0.4	20	5
4	DTE4-040	●	●	●	●	●	4	0.4	20	5

DGG External and face grooving

Ground

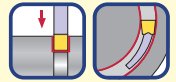
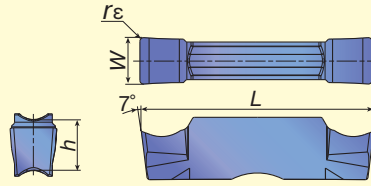

Insert seat size	Cat. No.	Grades		Dimensions (mm)			
		Cermet	Carbide	$W \pm 0.02$	$r_{\epsilon} \pm 0.05$	L	h
		NS9530	KS05F				
2	DGG200-020	●	●	2	0.2	20	5.0
3	DGG300-020	●	●	3	0.2	20	5.0
4	DGG400-040	●	●	4	0.4	20	5.0
5	DGG500-040	●	●	5	0.4	25	5.5
6	DGG600-040	●	●	6	0.4	25	5.5

DTX External, internal, face grooving and turning

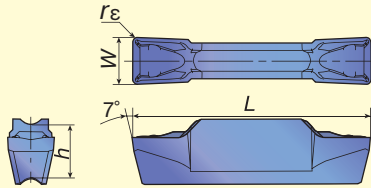

Insert seat size	Cat. No.	Grades					Dimensions (mm)			
		Coated				Cermet	$W \pm 0.05$	r_{ϵ}	L	h
		T9125	NEW AH7025	AH725	GH130					
3	DTX3-030	●	●	●	●	●	3	0.3	20	5.0
4	DTX4-040	●	●	●	●	●	4	0.4	20	5.0
5	DTX5-040	●	●	●	●	●	5	0.4	25	5.5
6	DTX6-080			●	●		6	0.8	25	5.5

DTF Face grooving and turning

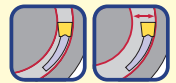
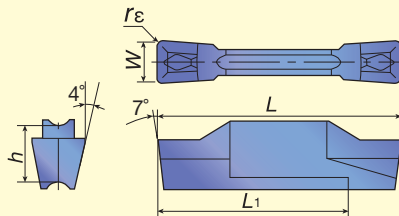

Right-hand (R) shown.

Insert seat size	Cat. No.	Grades								Dimensions (mm)					
		Coated						Cermet		$W \pm 0.05$	r_{ϵ}	L	h	L_1	
		T9125		AH725		GH130		NS9530							
		R	L	R	L	R	L	R	L						
3	DTF3-040-R/L	●	●	●	●	●	●	●	●	●	3	0.4	20	5	16
4	DTF4-040-R/L	●	●	●	●	●	●	●	●	●	4	0.4	20	5	16

Apply right-hand inserts on right-hand toolholders and left-hand inserts on left-hand toolholders.

● : Stocked items

DTI

Internal grooving and turning

Ground

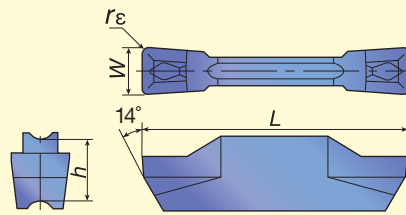

Insert seat size	Cat. No.	Grades				Dimensions (mm)			
		Coated			Cermet	$W \pm 0.02$	$r_{\epsilon} \pm 0.05$	L	h
		T9125	AH725	GH130					
3	DTI300-040	●	●	●	●	3	0.4	20	5
4	DTI400-040	●	●	●	●	4	0.4	20	5
4	DTI400-080	●	●	●	●	4	0.8	20	5
5	DTI500-040	●	●	●	●	5	0.4	25	5.5
5	DTI500-080	●	●	●	●	5	0.8	25	5.5
6	DTI600-080	●	●	●		6	0.8	25	5.5
6	DTI600-120	●	●	●		6	1.2	25	5.5
8	DTI800-080	●	●	●		8	0.8	30	6.7
8	DTI800-120	●	●	●		8	1.2	30	6.7

DTI

Internal grooving and turning

Molded

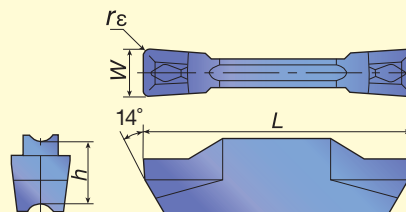

Insert seat size	Cat. No.	Grades					Dimensions (mm)			
		Coated				Cermet	$W \pm 0.05$	r_{ϵ}	L	h
		T9125	AH7025 <small>NEW</small>	AH725	GH130					
3	DTI3-040	●	●	●	●	●	3	0.4	20	5
4	DTI4-040	●		●	●	●	4	0.4	20	5

DGIM

Small diameter internal grooving

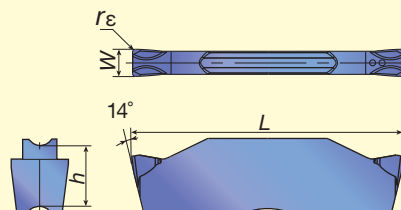

Insert seat size	Cat. No.	Grades				Dimensions (mm)			
		Coated			Cermet	$W \pm 0.05$	r_{ϵ}	L	h
		T9125	AH725	GH130					
2	DGIM2-020	●	●	●	●	2	0.2	20	5

● : Stocked items

DGIS Small diameter internal grooving

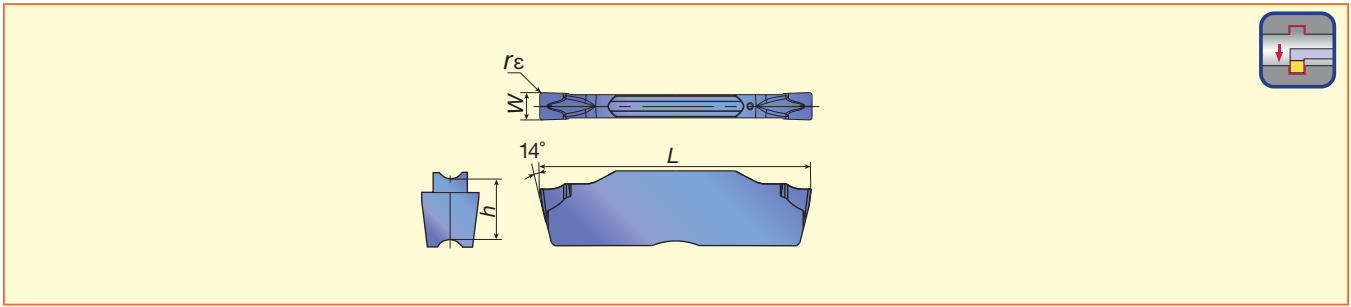

Insert seat size	Cat. No.	Grades				Dimensions (mm)			
		Coated			Cermet	$W \pm 0.05$	r_ϵ	L	h
		T9125	AH725	GH130	NS9530				
2	DGIS2-020	●	●	●	●	2	0.2	20	5

DTR Profiling and undercutting

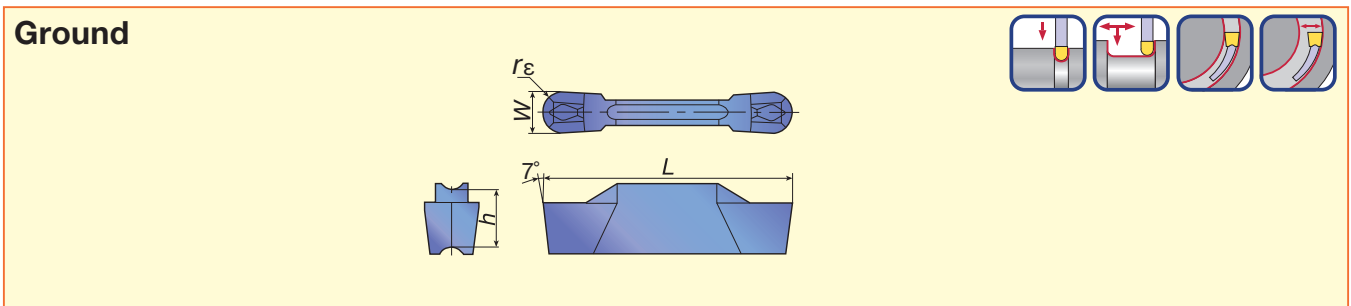

Insert seat size	Cat. No.	Grades				Dimensions (mm)			
		Coated			Cermet	$W \pm 0.02$	r_ϵ	L	h
		T9125	AH725	GH130	NS9530				
3	DTR300-150	●	●	●	●	3.00	1.50	20	5.0
4	DTR400-200	●	●	●	●	4.00	2.00	20	5.0
5	DTR478-239	●	●	●	●	4.78	2.39	25	5.5
5	DTR500-250	●	●	●	●	5.00	2.50	25	5.5
6	DTR600-300	●	●	●	●	6.00	3.00	25	5.5

DTR Profiling and undercutting

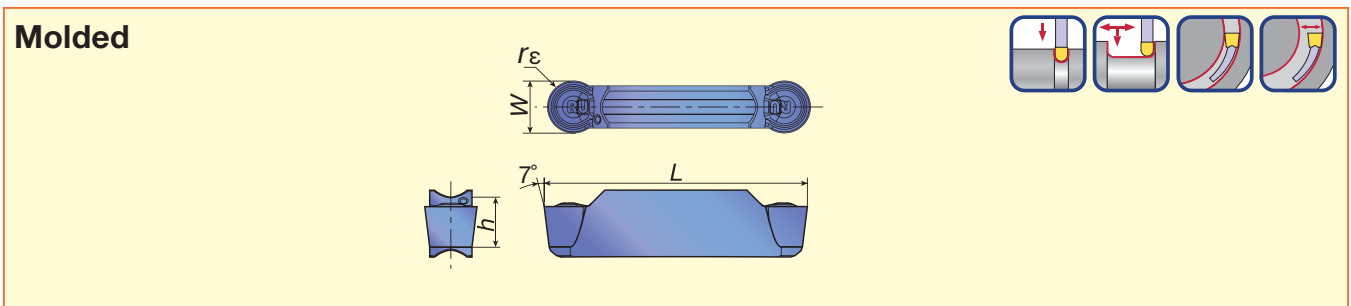

Insert seat size	Cat. No.	Grades						Dimensions (mm)			
		Coated					Cermet	$W \pm 0.05$	r_ϵ	L	h
		T9125	NEW AH7025	AH725	AH905	GH130	NS9530				
3	DTR3-150	●	●	●	●	●	●	3	1.5	20	5.0
4	DTR4-200	●	●	●	●	●	●	4	2.0	20	5.0
5	DTR5-250	●	●	●	●	●	●	5	2.5	25	5.5
6	DTR6-300	●	●	●	●	●	●	6	3	25	5.5
8	DTR8-400	●	●	●	●	●	●	8	4	30	6.7

● : Stocked items

DTIU

Profiling and undercutting

Ground

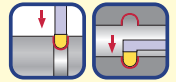
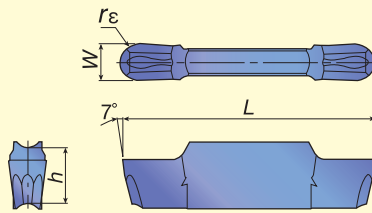

Insert seat size	Cat. No.	Grades		Dimensions (mm)			
		Coated		$W \pm 0.02$	r_E	L	h
		AH725	GH130				
3	DTIU300-150	●	●	3.00	1.50	20	5.0
4	DTIU400-200	●	●	4.00	2.00	20	5.0
5	DTIU500-250	●	●	5.00	2.50	25	5.5
6	DTIU600-300	●	●	6.00	3.00	25	5.5

DTA

Aluminium wheel machining

Ground

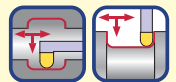
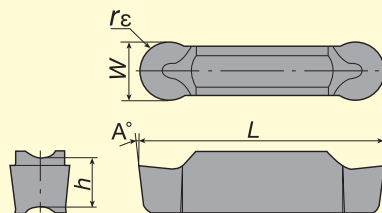

Insert seat size	Cat. No.	Grades	Dimensions (mm)				
		Carbide	$W \pm 0.02$	r_E	L	h	A
		TH10					
6	DTA600-300	●	6.00	3.00	25	5.5	7°
8	DTA800-400	●	8.00	4.00	30	6.7	10°

SGN

External grooving of hardened steels

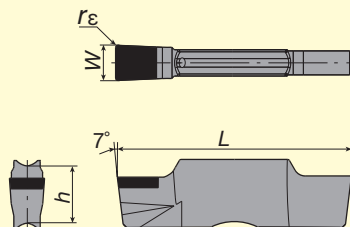

Insert seat size	Cat. No.	Grades	Dimensions (mm)			
		CBN	$W \pm 0.025$	r_E	L	h
		BX360				
2	SGN200-020	●	2.00	0.2	20	5.0
3	SGN300-020	●	3.00	0.2	20	5.0
4	SGN400-020	●	4.00	0.2	20	5.0

● : Stocked items

Toolholders

Mono block type

CTER/L External grooving and turning

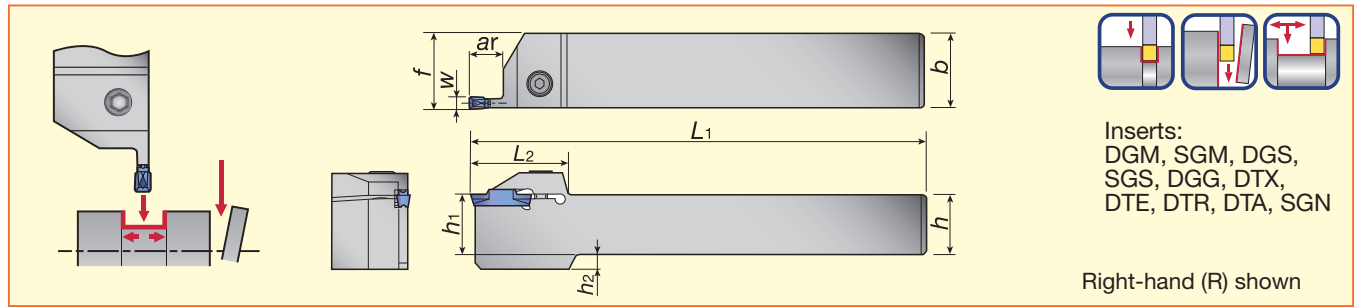

Insert seat size	Cat. No.	Stock		Max. groove depth ⁽¹⁾ ar (mm)	Dimensions (mm)								Parts	
		R	L		h ₁	b	h	L ₁	f ⁽²⁾	W	h ₂	L ₂	Clamping screw	Wrench
2	CTER/L1616-2T08	●	●	8	16	16	16	110	16.1	2	4	33	CM5x0.8x16-A	P-4
2	CTER/L2020-2T08	●	●	8	20	20	20	125	20.1	2	-	33	CM5x0.8x20-A	P-4
2	CTER/L2525-2T08	●	●	8	25	25	25	150	25.1	2	-	33	CM5x0.8x25-A	P-4
2	CTER/L1616-2T12	●	●	12	16	16	16	110	16.1	2	4	32	CM5x0.8x16-A	P-4
2	CTER/L2020-2T12	●	●	12	20	20	20	125	20.1	2	-	32	CM5x0.8x20-A	P-4
2	CTER/L2525-2T12	●	●	12	25	25	25	150	25.1	2	-	32	CM5x0.8x25-A	P-4
2	CTER/L1616-2T17	●	●	17	16	16	16	110	16.1	2	4	37	CM5x0.8x16-A	P-4
2	CTER/L2020-2T17	●	●	17	20	20	20	125	20.1	2	-	37	CM5x0.8x20-A	P-4
2	CTER/L2525-2T17	●	●	17	25	25	25	150	25.1	2	-	37	CM5x0.8x25-A	P-4
3	CTER/L1616-3T09	●	●	9	16	16	16	110	16.3	3	4	32	CM5x0.8x16-A	P-4
3	CTER/L2020-3T09	●	●	9	20	20	20	125	20.3	3	-	32	CM5x0.8x20-A	P-4
3	CTER/L2525-3T09	●	●	9	25	25	25	150	25.3	3	-	32	CM5x0.8x25-A	P-4
3	CTER/L2020-3T12	●	●	12	20	20	20	125	20.3	3	-	32	CM5x0.8x20-A	P-4
3	CTER/L2525-3T12	●	●	12	25	25	25	150	25.3	3	-	32	CM5x0.8x25-A	P-4
3	CTER/L1616-3T20	●	●	20	16	16	16	110	16.3	3	4	38.5	CM5x0.8x16-A	P-4
3	CTER/L2020-3T20	●	●	20	20	20	20	125	20.3	3	-	38.5	CM5x0.8x20-A	P-4
3	CTER/L2525-3T20	●	●	20	25	25	25	150	25.3	3	-	38.5	CM5x0.8x25-A	P-4
3	CTER/L2525-3T25	●	●	25	25	25	25	150	25.3	3	-	44.5	CM5x0.8x25-A	P-4
4	CTER/L1616-4T10	●	●	10	16	16	16	110	16.5	4	4	32	CM6x1x16-A	P-5
4	CTER/L2020-4T10	●	●	10	20	20	20	125	20.5	4	-	32	CM6x1x20-A	P-5
4	CTER/L2525-4T10	●	●	10	25	25	25	150	25.5	4	-	32	CM6x1x25-A	P-5
4	CTER/L2020-4T15	●	●	15	20	20	20	125	20.5	4	-	33	CM6x1x20-A	P-5
4	CTER/L2525-4T15	●	●	15	25	25	25	150	25.6	4	-	33	CM6x1x25-A	P-5
4	CTER/L1616-4T25	●	●	25	16	16	16	110	16.5	4	4	45	CM6x1x16-A	P-5
4	CTER/L2020-4T25	●	●	25	20	20	20	125	20.5	4	-	45	CM6x1x20-A	P-5
4	CTER/L2525-4T25	●	●	25	25	25	25	150	25.5	4	-	45	CM6x1x25-A	P-5
4	CTER/L3232-4T25	●	●	25	32	32	32	170	32.5	4	-	45	CM6x1x25-A	P-5
5	CTER/L2020-5T12	●	●	12	20	20	20	125	20.6	5	-	37	CM6x1x20-A	P-5
5	CTER/L2525-5T12	●	●	12	25	25	25	150	25.6	5	-	37	CM6x1x25-A	P-5
5	CTER/L2525-5T20	●	●	20	25	25	25	150	25.6	5	-	37	CM6x1x25-A	P-5
5	CTER/L2525-5T32	●	●	32	25	25	25	150	25.5	5	-	56	CM6x1x25-A	P-5
5	CTER/L3232-5T32	●	●	32	32	32	32	170	32.5	5	-	56	CM6x1x25-A	P-5
6	CTER/L2020-6T12	●	●	12	20	20	20	125	20.6	6	-	37	CM8x1.25x20-A	P-6
6	CTER/L2525-6T12	●	●	12	25	25	25	150	25.6	6	7	37	CM8x1.25x25-A	P-6
6	CTER/L2525-6T20	●	●	20	25	25	25	150	25.6	6	-	41	CM8x1.25x25-A	P-6
6	CTER/L2525-6T32	●	●	32	25	25	25	150	25.5	6	7	56	CM8x1.25x25-A	P-6
6	CTER/L3232-6T32	●	●	32	32	32	32	170	32.5	6	-	56	CM8x1.25x25-A	P-6
8	CTER/L2525-8T16	●	●	16	25	25	25	150	26.1	8	7	47	CM8x1.25x25-A	P-6
8	CTER/L2525-8T25	●	●	25	25	25	25	150	26.1	8	7	47	CM8x1.25x25-A	P-6
8	CTER/L3232-8T25	●	●	25	32	32	32	170	33.1	8	-	47	CM8x1.25x25-A	P-6
8	CTER/L2525-8T36	●	●	36	25	25	25	150	26.1	8	7	60	CM8x1.25x25-A	P-6
8	CTER/L3232-8T36	●	●	36	32	32	32	170	33.1	8	-	60	CM8x1.25x25-A	P-6

(1) When depth is deeper than insert length, 1 corner type is recommended.
 (2) "f" value in the above table is calculated with groove width "W" shown in the table.

CTEFR/L External and face grooving and turning

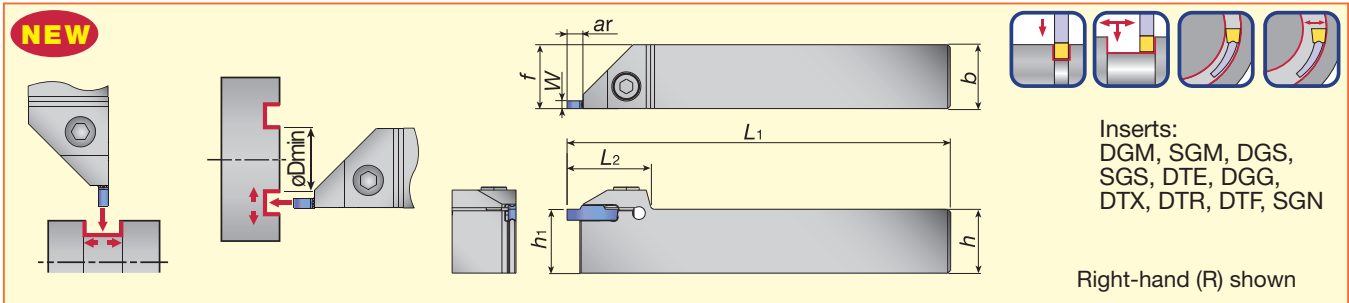

Insert seat size	Cat. No.	Stock		Max. groove depth ar (mm)	Dimensions (mm)						Parts		
		R	L		h_1	b	h	L_1	$f^{(2)}$	W	L_2	Clamping screw	Wrench
2, 3, 4	CTEFR/L2020-4T04	●	●	4.8	20	20	20	125	20.5	4	33	CM6x1x20-A	P-5
2, 3, 4	CTEFR/L2525-4T04	●	●	4.8	25	25	25	150	25.5	4	33	CM6x1x25-A	P-5
5, 6	CTEFR/L2020-6T04	●	●	4.8	20	20	20	125	20.6	6	37	CM6x1x20-A	P-5
5, 6	CTEFR/L2525-6T04	●	●	4.8	25	25	25	150	25.6	6	37	CM6x1x25-A	P-5

(1) "f" value in the above table is calculated with groove width "W" shown in the table.

Inserts	Groove width W (mm)	Min. dia. for face grooving øDmin (mm)
DGM / DGS / SGN	2	295
DGM / DGS / SGN	3	92
DGM / DGS / SGN	4	37
DGM / DGS	5	60
DGM / DGS	6	57
DTE / DGG	3	62
DTE / DGG	4	42
DTE / DGG	5	64
DTE / DGG	6	61

Inserts	Groove width W (mm)	Min. dia. for face grooving øDmin (mm)
DTR	3	44
DTR	4	32
DTR	5	48
DTR	6	48
DTX	3	19
DTX	4	20
DTX	5	20
DTX	6	23
DTF	3	19
DTF	4	20

CGEUR/L External undercutting

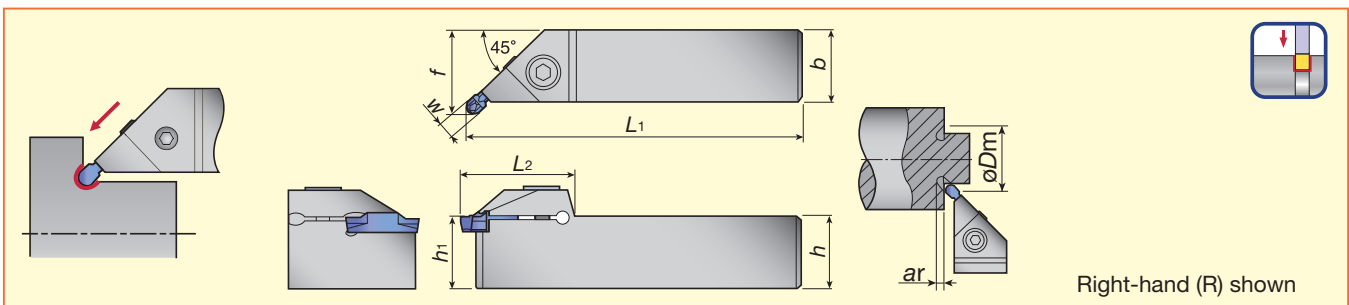

Insert seat size	Cat. No.	Stock		Min. dia. øDm (mm)	Max. groove depth ar (mm)	Dimensions (mm)						Inserts	Parts		
		R	L			b	h	L_1	$f^{(1)}$	W	h_1		L_2	Clamping screw	Wrench
3	CGEUR/L1616-3T02	●	●	32	2.8	16	16	110	19.3	3	16	30	DTIU	CM5x0.8x16-A	P-4
3	CGEUR/L2020-3T02	●	●	32	2.8	20	20	125	23.3	3	20	30	DTIU	CM5x0.8x16-A	P-4
3	CGEUR/L2525-3T02	●	●	32	2.8	25	25	150	28.3	3	25	30	DTIU	CM5x0.8x16-A	P-4
4	CGEUR/L1616-4T02	●	●	32	2.8	16	16	110	19.5	4	16	31	DTIU	CM6x1x16-A	P-5
4	CGEUR/L2020-4T02	●	●	32	2.8	20	20	125	23.5	4	20	31	DTIU	CM6x1x20-A	P-5
4	CGEUR/L2525-4T02	●	●	32	2.8	25	25	150	28.5	4	25	31	DTIU	CM6x1x25-A	P-5
5, 6	CGEUR/L2525-6T03	●	●	34	3.4	25	25	150	28.9	6	25	35	DTIU	CM6x1x25-A	P-5

(1) "f" value in the above table is calculated with groove width "W" shown in the table.

CTIR/L

Internal grooving and turning

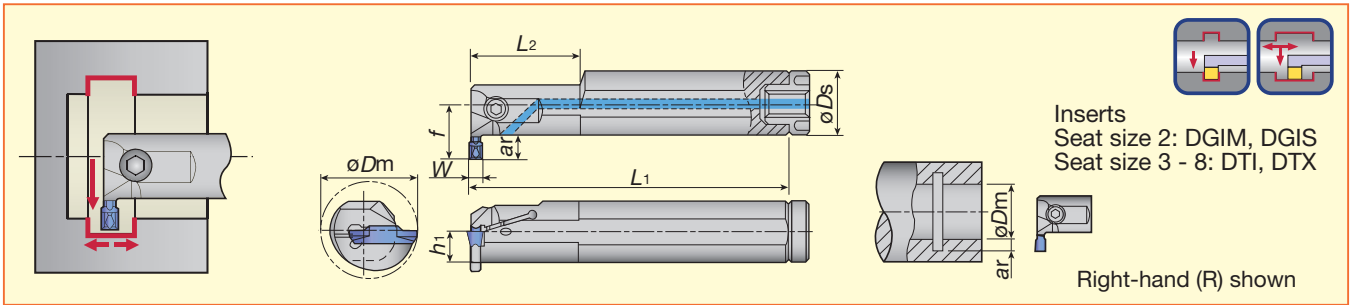

Insert seat size	Cat. No.	Stock		Min. dia. øDm (mm)	Max. groove depth ar (mm)	Dimensions (mm)						Parts				
		R	L			øDs	h ₁	h	L ₁ ⁽¹⁾	f	W	L ₂	Clamping screw	Wrench	Seal cap	Internal screw
2	CTIR/L16-2T08-D250	●	●	25	8	16	7.5	14	125	16.5	2	-	CM5x0.8x10-A	P-4	CA-16	M6
2	CTIR/L20-2T06-D250	●	●	25	6	20	9	18	160	15.8	2	-	CM5x0.8x12-A	P-4	CA-20	M6
3	CTIR/L20-3T06-D250	●	●	25	6	20	9	18	160	15.8	3	40	CM5x0.8x12-A	P-4	CA-20	M6
3	CTIR/L25-3T05-D250	●	●	25	5.1	25	11.5	23	200	17.5	3	40	CM5x0.8x16-A	P-4	CA-25	R1/8"
3	CTIR/L25-3T08-D320	●	●	32	8	25	11.5	23	200	21.5	3	40	CM5x0.8x16-A	P-4	CA-25	R1/8"
3	CTIR/L32-3T10-D400	●	●	40	10	32	15	30	250	27	3	60	CM5x0.8x16-A	P-4	CA-32	R1/8"
4	CTIR/L20-4T06-D250	●	●	25	6	20	9	18	160	15.8	4	40	CM5x0.8x12-A	P-4	CA-20	M6
4	CTIR/L25-4T08-D320	●	●	32	8	25	11.5	23	200	21.5	4	40	CM5x0.8x16-A	P-4	CA-25	R1/8"
4	CTIR/L32-4T04-D310	●	●	31	4	32	15	30	250	20.8	4	60	CM5x0.8x16-A	P-4	CA-32	R1/8"
4	CTIR/L32-4T10-D400	●	●	40	10	32	15	30	250	27	4	60	CM5x0.8x16-A	P-4	CA-32	R1/8"
5	CTIR/L25-5T05-D310	●	●	31	5	25	11.5	23	200	17.3	5	60	CM6x1x16-A	P-5	CA-25	R1/8"
5	CTIR/L32-5T10-D400	●	●	40	10	32	15	30	250	27	5	60	CM6x1x20-A	P-5	CA-32	R1/8"
6	CTIR/L32-6T04-D310	●	●	31	4	32	15	30	250	20.8	6	60	CM6x1x20-A	P-5	CA-32	R1/8"
6	CTIR/L32-6T10-D400	●	●	40	10	32	15	30	250	27	6	60	CM6x1x20-A	P-5	CA-32	R1/8"
8	CTIR/L32-8T05-D370	●	●	37	5	32	15	30	250	21.3	8	60	CM6x1x25-A	P-5	CA-32	R1/8"
8	CTIR/L40-8T05-D420	●	●	42	5.8	40	19	38	300	25.8	8	65	CM6x1x25-A	P-5	CA-40	R1/8"

(1) "L₁" value in the above table is calculated with groove width "W" shown in the table.

CTIFR/L

Internal face grooving and turning

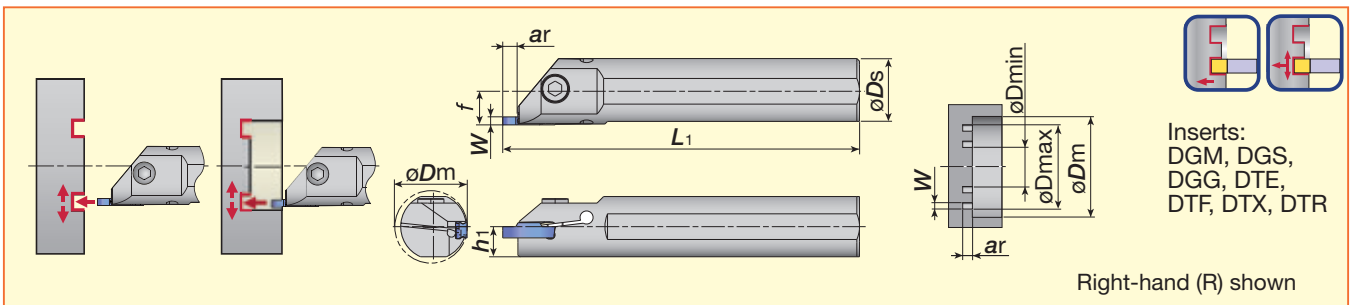

Insert seat size	Cat. No.	Stock		Max. groove depth ar (mm)	Dimensions (mm)						Parts	
		R	L		øDs	h ₁	h	L ₁ ⁽¹⁾	f	W	Clamping screw	Wrench
3, 4	CTIFR/L25-4T05-D270	●	●	5.5	25	11.5	11.5	200	13.3	4	CM6x1x16-A	P-5
3, 4	CTIFR/L32-4T05-D340	●	●	5.5	32	15	15	250	16.8	4	CM6x1x20-A	P-5
5, 6	CTIFR/L25-5T05-D270	●	●	5.5	25	11.5	11.5	200	13.3	6	CM6x1x16-A	P-5
5, 6	CTIFR/L32-5T05-D340	●	●	5.5	32	15	15	250	16.8	6	CM6x1x20-A	P-5

Insert seat size	Min. bore dia. øDm (mm)		øDmin (mm)				øDmax (mm)
	øDs = 25 mm	øDs = 32 mm	DGM, DGS, DGG	DTE	DTF / DTX	DTR	
3	26.3	33.3	92	62	19	44	∞
4	26.8	33.8	37	42	20	32	∞
5	26.3	33.3	60	64	20	48	∞
6	26.8	33.8	57	61	23	48	∞

● : Stocked items

CGIUR/L

Internal undercutting

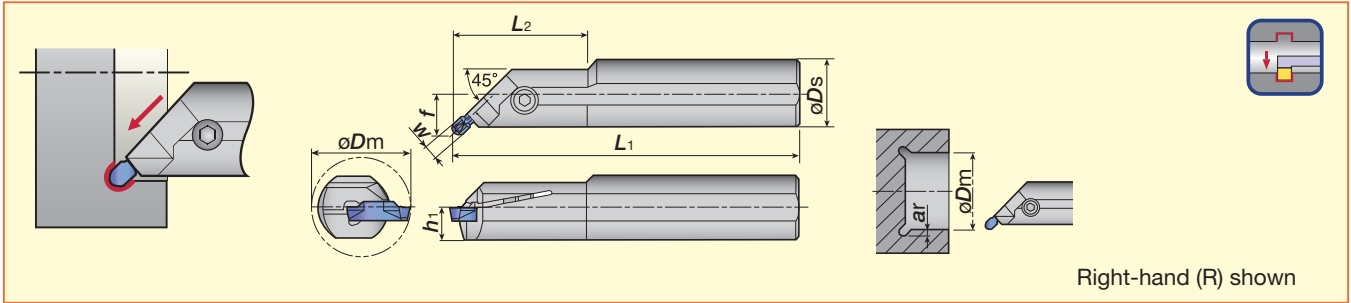

Right-hand (R) shown

Insert seat size	Cat. No.	Stock		Min. dia. øDm (mm)	Max. groove depth ar (mm)	Dimensions (mm)						Inserts	Parts		
		R	L			øDs	h1	h	L1	f ⁽¹⁾	W		L2	Clamping screw	Wrench
3	CGIUR/L 20-3T02-D380	●	●	38	2.8	20	9.5	19	160	12.8	3	-	DTIU	CM5x0.8x12-A	P-4
3	CGIUR/L 25-3T02-D380	●	●	38	2.8	25	11.5	23	200	14.8	3	40	DTIU	CM5x0.8x16-A	P-4
4	CGIUR/L 20-4T02-D380	●	●	38	2.8	20	9.5	19	160	12.9	4	-	DTIU	CM5x0.8x16-A	P-4
4	CGIUR/L 25-4T02-D460	●	●	46	2.8	25	11.5	23	200	14.9	4	40	DTIU	CM5x0.8x16-A	P-4
5, 6	CGIUR/L 25-6T02-D460	●	●	46	2.8	25	11.5	23	200	15.2	6	-	DTIU	CM6x1x16-A	P-5

(1) "f" value in the above table is calculated with groove width "W" shown in the table.

CTFR/L

Face grooving and turning

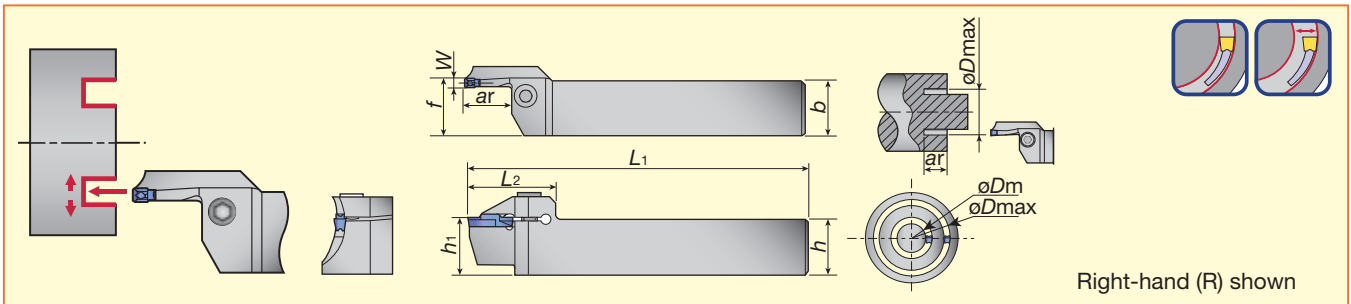

Right-hand (R) shown

Insert seat size	Cat. No.	Stock		Min. dia. øDm (mm)	Max. dia. øDm (mm)	Max. groove depth ⁽¹⁾ ar (mm)	Dimensions (mm)						Parts		
		R	L				h1	b	h	L1	f ⁽³⁾	W	L2	Clamping screw	Wrench
3	CTFR/L2525-3T10-024035	●	●	24	35	10	25	25	25	150	25.5	3	38	CM6x1x25-A	P-5
3	CTFR/L2525-3T10-029040	●	●	29	40	10	25	25	25	150	25.5	3	38	CM6x1x25-A	P-5
3	CTFR/L2525-3T10-034050	●	●	34	50	10	25	25	25	150	25.5	3	38	CM6x1x25-A	P-5
3	CTFR/L2525-3T15-044070	●	●	44	70	15	25	25	25	150	25.5	3	38	CM6x1x25-A	P-5
3	CTFR/L2525-3T15-064100	●	●	64	100	15	25	25	25	150	25.5	3	38	CM6x1x25-A	P-5
4	CTFR/L2525-4T10-022036	●	●	22	36	10	25	25	25	150	25.6	4	39	CM6x1x25-A	P-5
4	CTFR/L2525-4T20-028042	●	●	28	42	20 ⁽²⁾	25	25	25	150	25.6	4	39	CM6x1x25-A	P-5
4	CTFR/L2525-4T20-034050	●	●	34	50	20 ⁽²⁾	25	25	25	150	25.6	4	39	CM6x1x25-A	P-5
4	CTFR/L2525-4T20-042070	●	●	42	70	20	25	25	25	150	25.6	4	39	CM6x1x25-A	P-5
4	CTFR/L2525-4T20-062120	●	●	62	120	20	25	25	25	150	25.6	4	39	CM6x1x25-A	P-5
4	CTFR/L2525-4T20-112200	●	●	112	200	20	25	25	25	150	25.6	4	39	CM6x1x25-A	P-5
5	CTFR/L2525-5T25-050080	●	●	50	80	25	25	25	25	150	25.6	5	49	CM8x1.25x25-A	P-6
5	CTFR/L2525-5T25-070110	●	●	70	110	25	25	25	25	150	25.6	5	49	CM8x1.25x25-A	P-6
5	CTFR/L2525-5T25-100150	●	●	100	150	25	25	25	25	150	25.6	5	49	CM8x1.25x25-A	P-6
5	CTFR/L2525-5T25-140200	●	●	140	200	25	25	25	25	150	25.6	5	49	CM8x1.25x25-A	P-6
6	CTFR/L2525-6T25-048070	●	●	48	70	25	25	25	25	150	25.6	6	49	CM8x1.25x25-A	P-6
6	CTFR/L2525-6T25-058100	●	●	58	100	25	25	25	25	150	25.6	6	49	CM8x1.25x25-A	P-6
6	CTFR/L2525-6T25-088180	●	●	88	180	25	25	25	25	150	25.6	6	49	CM8x1.25x25-A	P-6
6	CTFR/L2525-6T25-168400	●	●	168	400	25	25	25	25	150	25.6	6	49	CM8x1.25x25-A	P-6

Insert seat size	Cat. No.	Inserts
3	CTFR/L2525-3T10-024035	DTF, DTX
3	CTFR/L2525-3T10-029040	DTF, DTX
3	CTFR/L2525-3T10-034050	DTF, DTX
3	CTFR/L2525-3T15-044070	DTF, DTX, DTE, DTR
3	CTFR/L2525-3T15-064100	DTF, DTX, DTE, DGG, DGM, DGS, DTR
4	CTFR/L2525-4T10-022036	DTF, DTX
4	CTFR/L2525-4T20-028042	DTF, DTX
4	CTFR/L2525-4T20-034050	DTF, DTX
4	CTFR/L2525-4T20-042070	DTF, DTX, DTE, DGG, DGM, DGS, DTR
4	CTFR/L2525-4T20-062120	DTF, DTX, DTE, DGG, DGM, DGS, DTR
4	CTFR/L2525-4T20-112200	DTF, DTX, DTE, DGG, DGM, DGS, DTR
5	CTFR/L2525-5T25-...	DTX, DTE, DGG, DGM, DGS, DTR
6	CTFR/L2525-6T25-...	DTX, DTE, DGG, DGM, DGS, DTR

(1) When depth is deeper than insert length, 1 corner type is recommended.

(2) When DTF insert is installed, Max. "ar" should be 15 mm.

(3) "f" value in the above table is calculated with groove width "W" shown in the table.

● : Stocked items

CTFVR/L Face grooving and turning

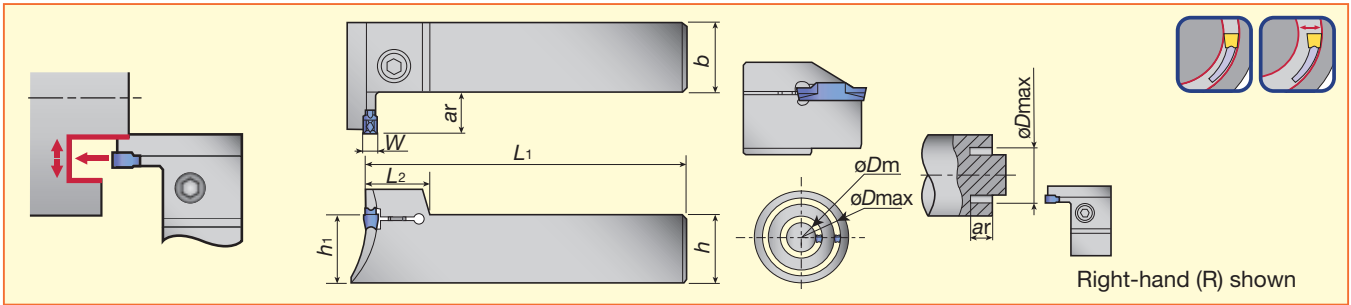

Insert seat size	Cat. No.	Stock			Dimensions (mm)							Parts		
		R	L	Min. dia. øDm (mm)	Max. dia. øDm (mm)	Max. groove depth ar (mm)	h1	b	h	L1	W	L2	Clamping screw	Wrench
3	CTFVR/L2525-3T10-024035	●	●	24	35	10	25	25	25	150	3	18	CM5x0.8x25-A	P-4
3	CTFVR/L2525-3T10-029040	●	●	29	40	10	25	25	25	150	3	18	CM5x0.8x25-A	P-4
3	CTFVR/L2525-3T10-034050	●	●	34	50	10	25	25	25	150	3	18	CM5x0.8x25-A	P-4
3	CTFVR/L2525-3T15-044060	●	●	44	60	15	25	25	25	150	3	18	CM5x0.8x25-A	P-4
3	CTFVR/L2525-3T15-054085	●	●	54	85	15	25	25	25	150	3	18	CM5x0.8x25-A	P-4
4	CTFVR/L2525-4T12-022040	●	●	22	40	12	25	25	25	150	4	18.5	CM6x1x25-A	P-5
4	CTFVR/L2525-4T15-032050	●	●	32	50	15	25	25	25	150	4	18.5	CM6x1x25-A	P-5
4	CTFVR/L2525-4T15-042060	●	●	42	60	15	25	25	25	150	4	18.5	CM6x1x25-A	P-5
4	CTFVR/L2525-4T15-052085	●	●	52	85	15	25	25	25	150	4	18.5	CM6x1x25-A	P-5
5	CTFVR/L2525-5T20-050080	●	●	50	80	20	25	25	25	150	5	22	CM8x1.25x25-A	P-6
5	CTFVR/L2525-5T20-070110	●	●	70	110	20	25	25	25	150	5	22	CM8x1.25x25-A	P-6
5	CTFVR/L2525-5T20-100150	●	●	100	150	20	25	25	25	150	5	22	CM8x1.25x25-A	P-6
5	CTFVR/L2525-5T20-140200	●	●	140	200	20	25	25	25	150	5	22	CM8x1.25x25-A	P-6
6	CTFVR/L2525-6T20-048085	●	●	48	85	20	25	25	25	150	6	22	CM8x1.25x25-A	P-6
6	CTFVR/L2525-6T20-073150	●	●	73	150	20	25	25	25	150	6	22	CM8x1.25x25-A	P-6
6	CTFVR/L2525-6T20-138250	●	●	138	250	20	25	25	25	150	6	22	CM8x1.25x25-A	P-6

Insert seat size	Cat. No.	Inserts
3	CTFVR/L2525-3T10-024035	DTF, DTX
3	CTFVR/L2525-3T10-029040	DTF, DTX
3	CTFVR/L2525-3T10-034050	DTF, DTX, DTR
3	CTFVR/L2525-3T15-044060	DTF, DTX, DTE, DTR
3	CTFVR/L2525-3T15-054085	DTF, DTX, DTE, DGG, DGM, DGS, DTR
4	CTFVR/L2525-4T12-022040	DTF, DTX
4	CTFVR/L2525-4T15-032050	DTF, DTX
4	CTFVR/L2525-4T15-042060	DTF, DTX, DTE, DGG, DGM, DGS, DTR
4	CTFVR/L2525-4T15-052085	DTF, DTX, DTE, DGG, DGM, DGS, DTR
5	CTFVR/L2525-5T20-...	DTX, DTE, DGG, DGM, DGS, DTR
6	CTFVR/L2525-6T20-...	DTX, DTE, DGG, DGM, DGS, DTR

(1) Min. diameter øDm of DTE, DGS and DGM insert

Inserts	øDm (mm)	Note
DTE3 / DGS3 / DGM3	ø92	When diameter is smaller than øDm, DTF or DTX type insert is recommended.
DTE4 / DGS4 / DGM4	ø42	

CTER/L-15A Internal profiling for aluminium wheel machining

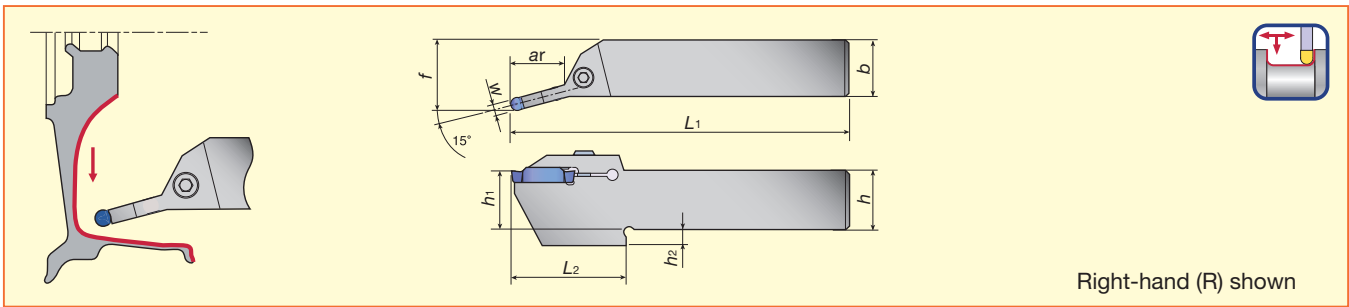

Right-hand (R) shown

Insert seat size	Cat. No.	Stock		Max. groove depth ar (mm)	Dimensions (mm)								Inserts	Parts	
		R	L		h_1	b	h	h_2	L_1	f	W	L_2		Clamping screw	Wrench
6	CTER/L2525-6T25-15A	●	●	25	25	25	25	7	150	32.2	6	50.5	DTA	CM6x1x25-A	P-5
8	CTER/L2525-8T30-15A	●	●	30	25	25	25	7	150	32.9	8	55	DTA	CM6x1x25-A	P-5

CGIUR/L-15A Internal profiling for aluminium wheel machining

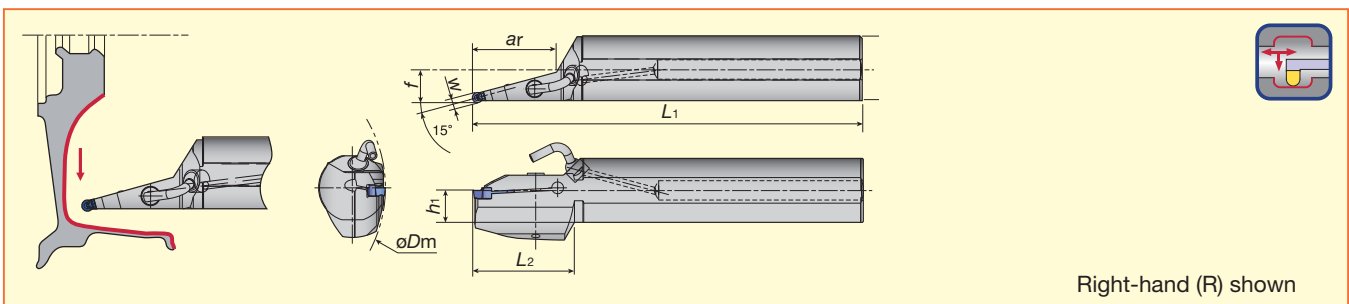

Right-hand (R) shown

Insert seat size	Cat. No.	Stock		Min. dia. øDm (mm)	Max. groove depth ar (mm)	Dimensions (mm)								Inserts	Parts			
		R	L			$øD_s$	h_1	h	L_1	f	W	L_2	Clamping screw		Wrench	Seal cap	Internal screw	
6	CGIUR/L40-6T50-D160-15A	●	●	160	50	40	19	38.5	320	19.7	6	60	DTA	CM6x1x25-A	P-5	CA-40	R1/8"	
8	CGIUR/L40-8T83-D160-15A	●	●	160	83	40	19	38.5	320	20.5	8	85	DTA	CM6x1x25-A	P-5	CA-40	R1/8"	
6	CGIUR/L50-6T85-D200-15A	●	●	200	85	50	23.5	48.5	350	25.2	6	85	DTA	CM6x1x25-A	P-5	CA-40	R1/8"	
8	CGIUR/L50-8T85-D200-15A	●	●	200	85	50	23.5	48.5	350	25.9	8	85	DTA	CM6x1x25-A	P-5	CA-40	R1/8"	

■ Nozzle parts

Coolant pipe	Coolant nozzle
PNZ5	CNZ125

JCTER/L Grooving for small lathes

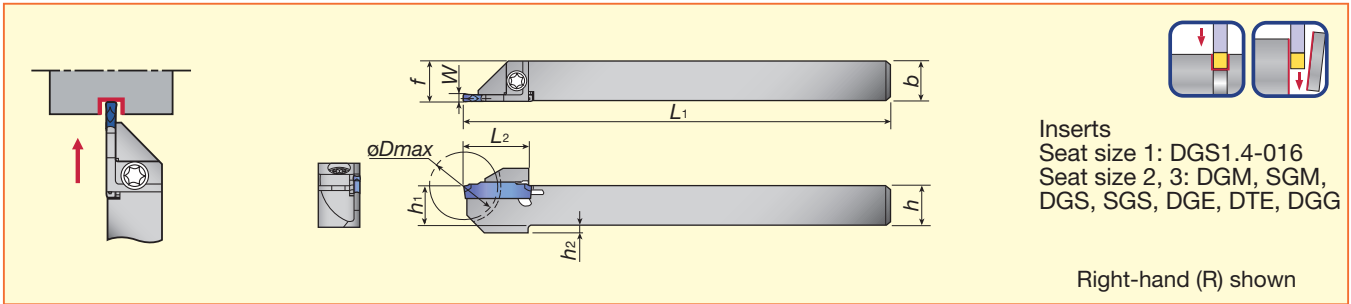

Inserts
 Seat size 1: DGS1.4-016
 Seat size 2, 3: DGM, SGM,
 DGS, SGS, DGE, DTE, DGG

Right-hand (R) shown

Insert seat size	Cat. No.	Stock		Max. dia. ϕD_{max} (mm)	Dimensions (mm)								Parts	
		R	L		h_1	b	h	L_1	$f^{(1)}$	W	h_2	L_2	Clamping screw	Wrench
1	JCTER/L1010-1.4T10	●	●	20	10	10	10	125	10.2	1.4	-	18	CSHB-4-A	T-15F
2	JCTER/L1010-2T10	●	●	20	10	10	10	125	10.1	2	2	19	CSHB-4-A	T-15F
1	JCTER/L1212-1.4T12	●	●	24	12	12	12	125	12.2	1.4	-	19.5	CSHB-4-A	T-15F
2	JCTER/L1212-2T12	●	●	24	12	12	12	125	12.1	2	2	19	CSHB-4-A	T-15F
3	JCTER/L1212-3T12	●	●	24	12	12	12	125	12.3	3	2	19	CSHB-4-A	T-15F
1	JCTER/L1414-1.4T12	●	●	24	14	14	14	125	14.2	1.4	-	19.5	CSHB-4-A	T-15F
2	JCTER/L1414-2T12	●	●	24	14	14	14	125	14.1	2	-	19	CSHB-4-A	T-15F
1	JCTER/L1616-1.4T16	●	●	32	16	16	16	125	16.2	1.4	-	24	CSHB-4-A	T-15F
2	JCTER/L1616-2T16	●	●	32	16	16	16	125	16.1	2	-	24	CSHB-4-A	T-15F
3	JCTER/L1616-3T16	●	●	32	16	16	16	125	16.3	3	-	24	CSHB-4-A	T-15F
3	JCTER/L2020-3T16	●	●	32	20	20	20	125	20.3	3	-	24	CSHB-4-A	T-15F
1	JCTER/L1010X1.4T10	●	●	20	10	10	10	120	10.2	1.4	-	18	CSHB-4-A	T-15F
2	JCTER/L1010X2T10	●	●	20	10	10	10	120	10.1	2	2	19	CSHB-4-A	T-15F
1	JCTER/L1212F1.4T12	●	●	24	12	12	12	85	12.2	1.4	-	19.5	CSHB-4-A	T-15F
1	JCTER/L1212X1.4T12	●	●	24	12	12	12	120	12.2	1.4	-	19.5	CSHB-4-A	T-15F
2	JCTER/L1212F2T12	●	●	24	12	12	12	85	12.1	2	2	19	CSHB-4-A	T-15F
2	JCTER/L1212X2T12	●	●	24	12	12	12	120	12.1	2	2	19	CSHB-4-A	T-15F
3	JCTER/L1212F3T12	●	●	24	12	12	12	85	12.3	3	2	19	CSHB-4-A	T-15F
3	JCTER/L1212X3T12	●	●	24	12	12	12	120	12.3	3	2	19	CSHB-4-A	T-15F
1	JCTER/L1616X1.4T16	●	●	32	16	16	16	120	16.2	1.4	-	24	CSHB-4-A	T-15F
2	JCTER/L1616X2T16	●	●	32	16	16	16	120	16.1	2	-	24	CSHB-4-A	T-15F
3	JCTER/L1616X3T16	●	●	32	16	16	16	120	16.3	3	-	24	CSHB-4-A	T-15F
3	JCTER/L2020H3T16	●	●	32	20	20	20	100	20.3	3	-	24	CSHB-4-A	T-15F

(1) "f" value in the above table is calculated with groove width "W" shown in the table.

CGER/L Deep grooving and parting off

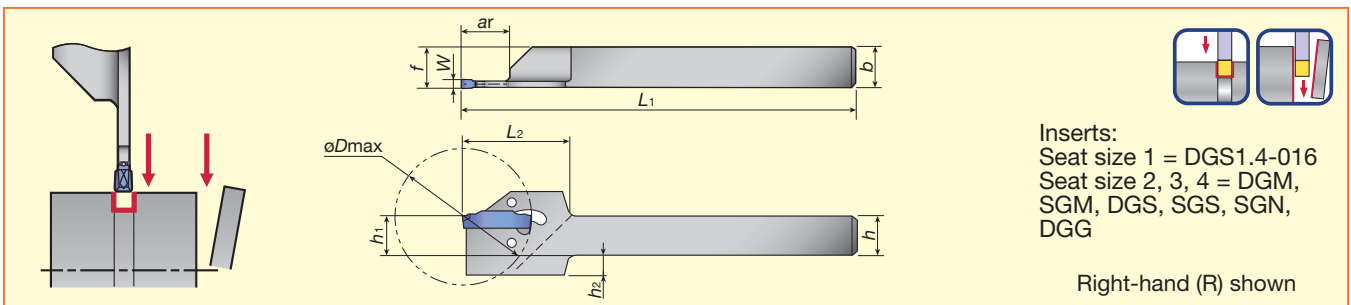

Inserts:
 Seat size 1 = DGS1.4-016
 Seat size 2, 3, 4 = DGM,
 SGM, DGS, SGS, SGN,
 DGG

Right-hand (R) shown

Insert seat size	Cat. No.	Stock		Max. dia. ϕD_{max} (mm)	Max. groove depth ar (mm)	Dimensions (mm)								Parts	
		R	L			DGS/M	SGS/M	h_1	b	h	L_1	$f^{(1)}$	W	h_2	L_2
1	CGER/L2020-1.4T14	●	●	29	29	9.7	20	20	20	125	20.2	1.4	-	30	CRW23
2	CGER/L1212-2T17	●	●	35	35	11.8	12	12	12	150	12.1	2	6	30	CRW33
2	CGER/L1616-2T17	●	●	35	35	11.8	16	16	16	150	16.1	2	2	30	CRW33
2	CGER/L2020-2T17	●	●	35	35	9.8	20	20	20	125	20.1	2	-	30	CRW33
3	CGER/L1212-3T19	●	●	38	40	12	12	12	12	150	12.3	3	6	30	CRW33
3	CGER/L1616-3T19	●	●	38	45	14.9	16	16	16	150	16.3	3	2	30	CRW33
3	CGER/L2020-3T19	●	●	38	45	13.2	20	20	20	125	20.3	3	-	30	CRW33
4	CGER/L2020-4T19	●	●	38	55	20.3	20	20	20	125	20.4	4	-	32	CRW33

(1) "f" value in the above table is calculated with groove width "W" shown in the table.

(2) Wrench, CRW□□, should be ordered separately. Please see information below about wrench usage.

● : Stocked items

CGP blades

CGP

Deep grooving and parting off

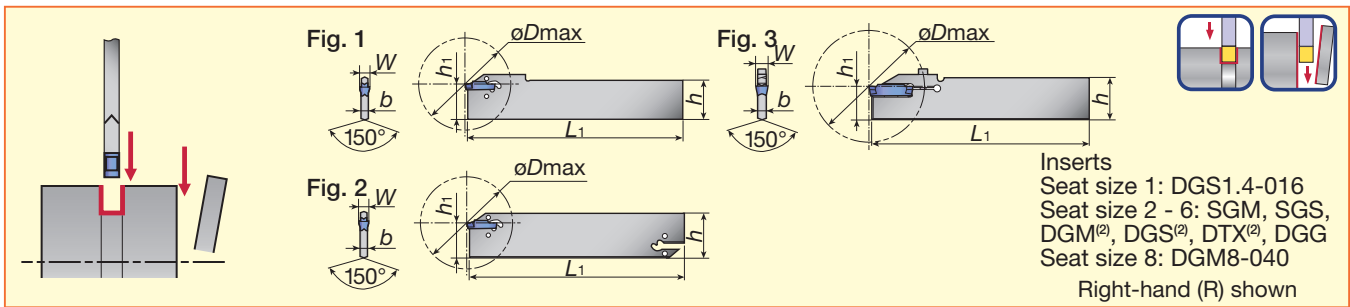

Insert seat size	Cat. No.	Stock	*Max. parting off dia. øDm (mm)	Dimensions (mm)					Parts		Fig.
				h ₁	b	h	L ₁	W	Clamping screw	Wrench ⁽³⁾	
1	CGP26-1.4S	●	26	21.4	1	26	150	1.4	-	CRW23	1
1	CGP32-1.4D	●	26	24.8	1	32	150	1.4	-	CRW23	2
2	CGP26-2S	●	40	21.4	1.8	26	150	2	-	CRW33	1
2	CGP32-2D	●	50	24.8	1.8	32	150	2	-	CRW33	2
3	CGP26-3S	●	50	21.4	2.4	26	150	3	-	CRW33	1
3	CGP32-3D	●	100	24.8	2.4	32	150	3	-	CRW33	2
4	CGP26-4S	●	80	21.4	3.2	26	150	4	-	CRW33	1
4	CGP32-4D	●	100	24.9	3.2	32	150	4	-	CRW33	2
4	CGP45-4D	●	120	38.1	3.2	45	150	4	-	CRW33	2
5	CGP32-5D	●	120	24.9	4	32	150	5	-	CRW33	2
6	CGP32-6D	●	120	24.9	5.2	32	150	6	-	CRW33	2
8	CGP32-8S-CL ⁽¹⁾	●	80	24.9	6.2	32	150	8	CM4x0.7x20-M0-A	P-3	3

- (1) Max groove depth is 28.5 mm.
- (2) When depth is deeper than insert length, 1 corner type is recommended.
- (3) Wrench, CRW□□, should be ordered separately.

Caution

Newly developed wrench

Insert is clamped by the elastic deformation of upper jaw. Low clamping stress increases the stability and tool life.

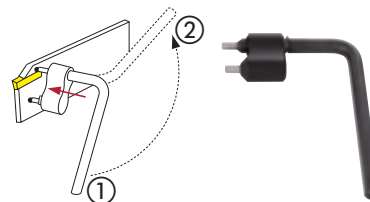

- ① → ② : unclamp
- ② → ① : clamp

Tool block for CGP blades

CTBF / CTBU

Deep grooving and parting off

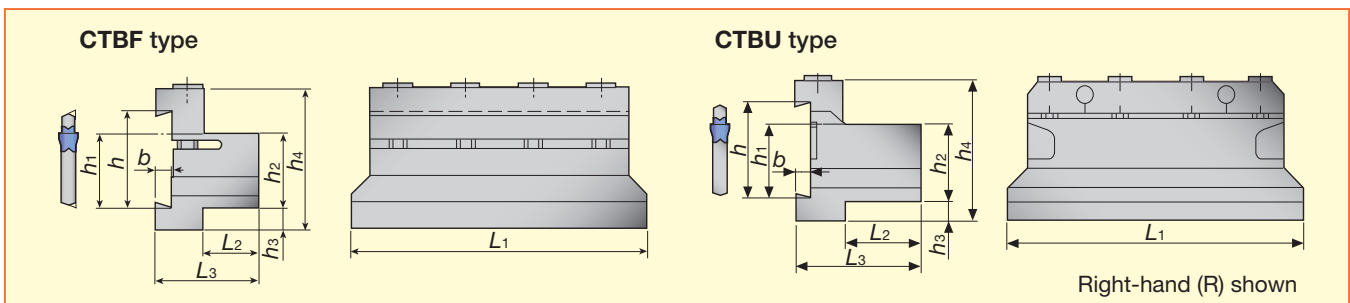

Cat. No.	Stock	Dimensions (mm)									Blade	Parts		
		h ₁	b	h	L ₁	h ₂	h ₃	h ₄	L ₂	L ₃		Clamping screw	Clamp	Wrench
CTBF25-45	●	38.1	5.5	45	110	25	25	66	22	40	CGP	CM6x1.0x40-A	-	P-5
CTBF32-45	●	38.1	5.5	45	120	32	18	66	28	45	CGP	CM6x1.0x40-A	-	P-5
CTBU20-26	●	21.4	4	26	86	20	9	43	21	38	CGP	CM6x30-S	CT-86	P-5
CTBU25-26	●	21.4	4	26	110	25	5	45	23	42	CGP	CM6x30-S	CT-105	P-5
CTBU20-32	●	24.8	5.3	32	100	20	13	50	19	38	CGP	CM6x30-S	CT-100	P-5
CTBU25-32	●	24.8	5.3	32	110	25	8	50	23	42	CGP	CM6x30-S	CT-110	P-5
CTBU32-32	●	24.8	5.3	32	110	32	5	54	29	48	CGP	CM6x30-S	CT-110	P-5

● : Stocked items

Blades (For general purpose)

CAER/L

External grooving and turning

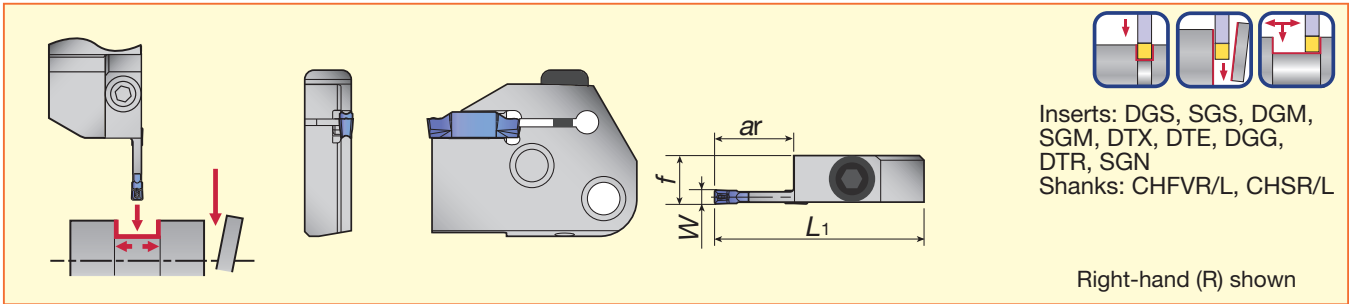

Insert seat size	Cat. No.	Stock		*Max. groove depth ar (mm)	Dimensions (mm)			Parts	
		R	L		L ₁	f	W	Clamping screw	Wrench
3	CAER/L-3T16	●	●	16	45	10.4	3	BHM6-20-A	P-4
4	CAER/L-4T16	●	●	16	45	10.5	4	BHM6-20-A	P-4
5	CAER/L-5T20	●	●	20	49	10.5	5	BHM6-20-A	P-4
6	CAER/L-6T20	●	●	20	49	10.5	6	BHM6-20-A	P-4

CAFR/L

Face grooving and turning

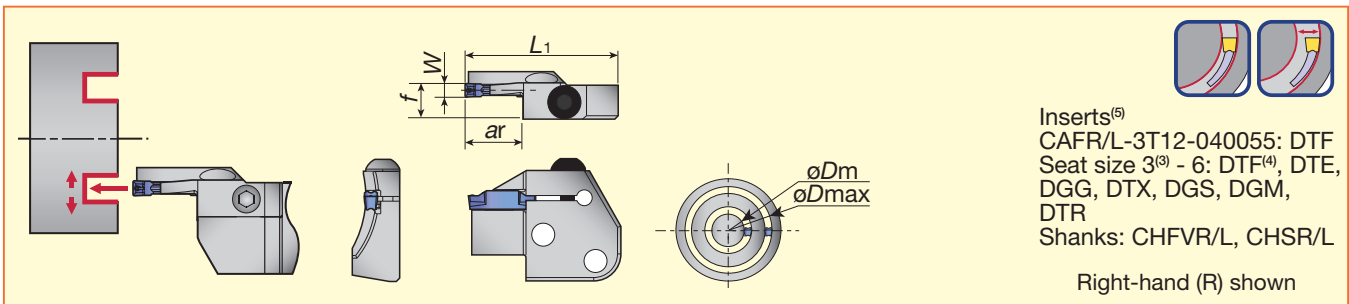

Insert seat size	Cat. No.	Stock		Min. dia. øDm (mm)	Max. dia. øDm (mm)	Max. groove depth ar (mm)	Dimensions (mm)			Parts	
		R	L				L ₁	f ⁽²⁾	W	Clamping screw	Wrench
3	CAFR/L-3T12-040055	●	●	40	55	12	45	10.4	3	BHM6-20-A	P-4
3	CAFR/L-3T12-055075	●	●	55	75	12	45	10.4	3	BHM6-20-A	P-4
3	CAFR/L-3T12-075100	●	●	75	100	12	45	10.4	3	BHM6-20-A	P-4
3	CAFR/L-3T12-100140	●	●	100	140	12	45	10.4	3	BHM6-20-A	P-4
3	CAFR/L-3T12-140200	●	●	140	200	12	45	10.4	3	BHM6-20-A	P-4
4	CAFR/L-4T16-050070	●	●	50	70	16	45	10.5	4	BHM6-20-A	P-4
4	CAFR/L-4T16-070100	●	●	70	100	16	45	10.5	4	BHM6-20-A	P-4
4	CAFR/L-4T16-100150	●	●	100	150	16	45	10.5	4	BHM6-20-A	P-4
4	CAFR/L-4T16-150250	●	●	150	250	16	45	10.5	4	BHM6-20-A	P-4
5	CAFR/L-5T20-055080	●	●	55	80	20	49	10.5	5	BHM6-20-A	P-4
5	CAFR/L-5T20-080120	●	●	80	120	20	49	10.5	5	BHM6-20-A	P-4
5	CAFR/L-5T20-120180	●	●	120	180	20	49	10.5	5	BHM6-20-A	P-4
5	CAFR/L-5T20-180300	●	●	180	300	20	49	10.5	5	BHM6-20-A	P-4
5	CAFR/L-5T20-300000	●	●	300	∞	20	49	10.5	5	BHM6-20-A	P-4
6	CAFR/L-6T25-060090	●	●	60	90	25 ⁽¹⁾	55	10.5	6	BHM6-20-A	P-4
6	CAFR/L-6T25-090150	●	●	90	150	25 ⁽¹⁾	55	10.5	6	BHM6-20-A	P-4
6	CAFR/L-6T25-150250	●	●	150	250	25 ⁽¹⁾	55	10.5	6	BHM6-20-A	P-4
6	CAFR/L-6T25-250400	●	●	250	400	25 ⁽¹⁾	55	10.5	6	BHM6-20-A	P-4

(1) When depth is deeper than insert length, 1 corner type is recommended.

(2) "f" value in the above table is calculated with groove width "W" shown in the table.

(3) Not applicable for CAFR/L-3T12-040055

(4) Seat sizes of DTF are only 3 and 4.

(5) Min. diameter øDm of DTE, DGS and DGM insert

Inserts	øDm (mm)	Note
DTE 3 / DGS 3 / DGM 3	ø92	When diameter is smaller than øDm, DTF or DTX type insert is recommended.
DTE 4 / DGS 4 / DGM 4	ø42	
DTE 5 / DGS 5 / DGM 5	ø64	
DTE 6 / DGS 6 / DGM 6	ø61	

● : Stocked items

Toolholders for blades

CHFVR/L Horizontal type

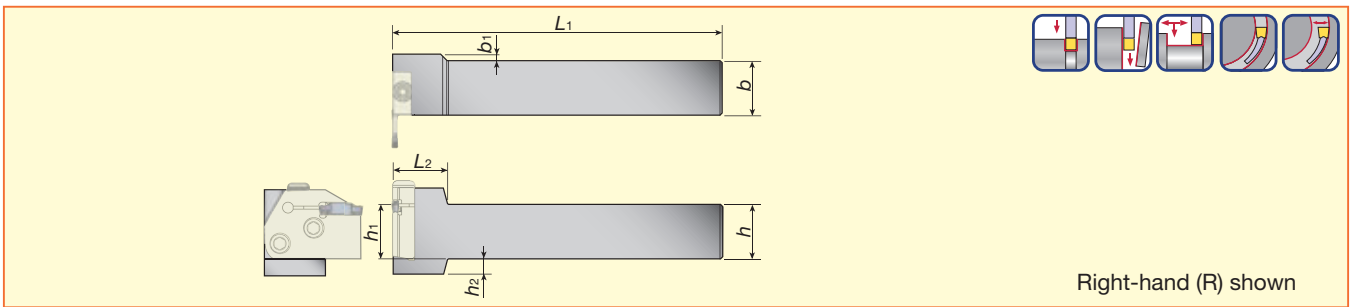

Cat. No.	Stock		Dimensions (mm)							Parts	
	R	L	h_1	b	h	L_1	b_1	h_2	L_2	Clamping screw	Wrench
CHFVR/L2020	●	●	20	20	20	150	8	12	25	CSHB-6-A	P-4
CHFVR/L2525	●	●	25	25	25	150	3	7	25	CSHB-6-A	P-4
CHFVR/L3232	●	●	32	32	32	170	-	-	25	CSHB-6-A	P-4

*Note: Blades = CAER/L, CAFR/L

C-CHFVR/L TUNGCAP Horizontal type

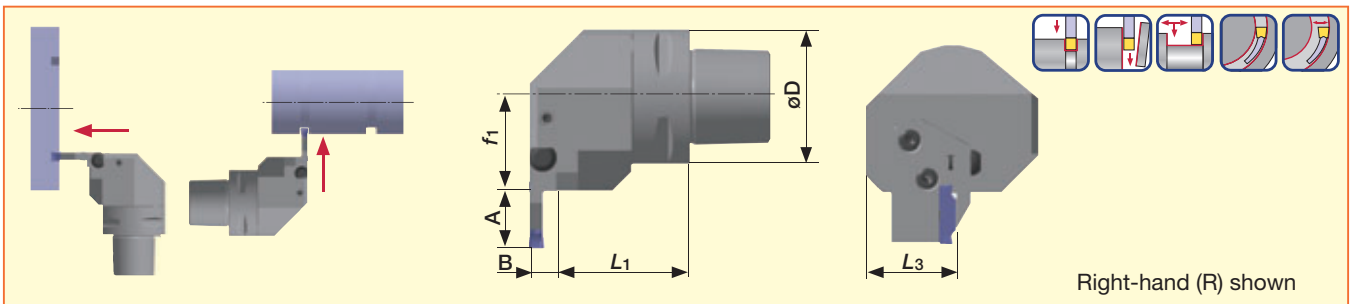

Cat. No.	Stock			Dimensions (mm)					Clamping screw	Wrench	Coolant nozzle	Coolant pipe
	R	L	ϕD	L_1	A^*	L_3	f_1	B^*				
C4CHFVR/L27050N ⁽²⁾			40	42.5	Table 1	36	27	Table 1	CSHB-6-A	P-4	(4)	-
C5CHFVR/L35060 ⁽¹⁾	●	●	50	49.5	Table 1	36	35	Table 1	CSHB-6-A	P-4	(3)	PNZ5
C5CHFVR/L35060N ⁽²⁾	●	●	50	49.5	Table 1	36	35	Table 1	CSHB-6-A	P-4	(4)	-
C6CHFVR/L45065 ⁽¹⁾	●	●	63	54.5	Table 1	41	45	Table 1	CSHB-6-A	P-4	(3)	PNZ5
C6CHFVR/L45065N ⁽²⁾	●	●	63	54.5	Table 1	41	45	Table 1	CSHB-6-A	P-4	(4)	-

(1) Capable for normal pressure coolant

(2) Capable for 7Mpa coolant pressure

(3) CNZ125 (4) SATZ-M10X1-M5

A*, B*: Please refer to the next page.

Combination of blade and toolholder

Toolholders	Blades			
	CAER□□□	CAEL□□□	CAFR□□□	CAFL□□□
CHFVR***		●	●	
CHFVL***	●			●

CHSR/L Vertical type

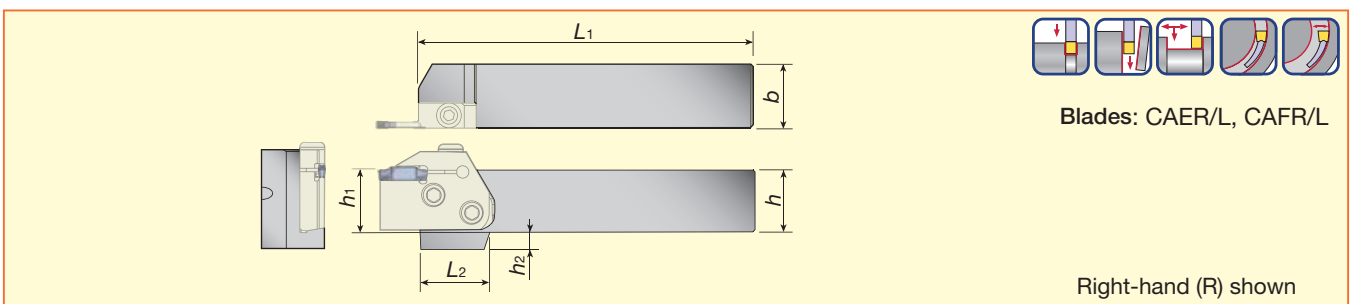

Cat. No.	Stock		Dimensions (mm)						Parts	
	R	L	h_1	b	h	L_1	h_2	L_2	Clamping screw	Wrench
CHSR/L2020	●	●	20	20	20	133	12	35	CSHB-6-A	P-4
CHSR/L2525	●	●	25	25	25	133	7	28	CSHB-6-A	P-4
CHSR/L3232	●	●	32	32	32	153	-	28	CSHB-6-A	P-4

● : Stocked items

C-CHSR/L TUNGCAP Vertical type

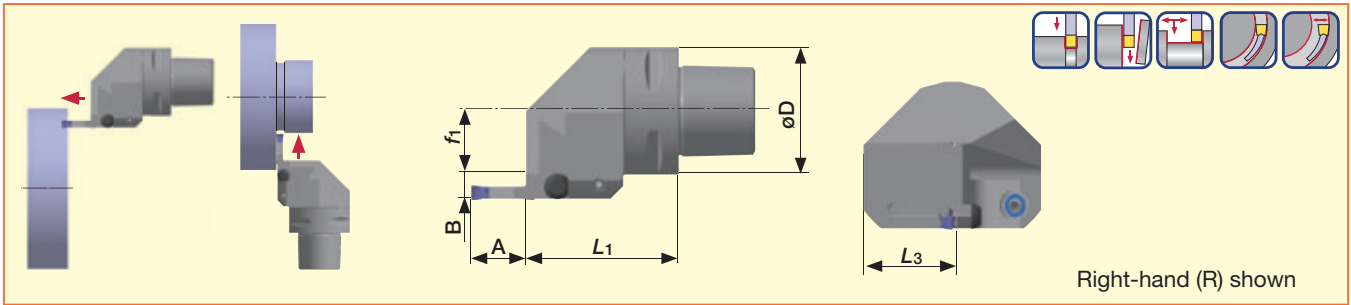

Cat. No.	Stock		Dimensions (mm)					Clamping screw	Wrench	Coolant nozzle	Coolant pipe	
	R	L	øD	L1	A*	L3	f1					B*
C4CHSR/L27050N ⁽²⁾	●	●	40	50	Table 1	36	16.5	Table 1	CSHB-6-A	P-4	(4)	-
C5CHSR/L35060 ⁽¹⁾	●	●	50	60	Table 1	36	24.5	Table 1	CSHB-6-A	P-4	(3)	PNZ5
C5CHSR/L35060N ⁽²⁾	●	●	50	60	Table 1	36	24.5	Table 1	CSHB-6-A	P-4	(4)	-
C6CHSR/L45065 ⁽¹⁾			63	65	Table 1	41	34.5	Table 1	CSHB-6-A	P-4	(3)	PNZ5
C6CHSR/L45065N ⁽²⁾	●	●	63	65	Table 1	41	34.5	Table 1	CSHB-6-A	P-4	(4)	-

- (1) Capable for normal pressure coolant
- (2) Capable for 7Mpa coolant pressure
- (3) CNZ125
- (4) SATZ-M10X1-M5

- : Stocked items
- ★ : Available in 2015

Combination of blade and toolholder

Toolholders	Blades			
	CAER□□□	CAEL□□□	CAFR□□□	CAFL□□□
CHSR***	●			●
CHSL***		●	●	

Table 1

Offset dimensions for blade

Application	Blades	Dimensions (mm)	
		A*	B*
For external grooving	CAER/L-3T16	16	10.4
	CAER/L-4T16	16	10.5
	CAER/L-5T20	20	10.5
	CAER/L-6T20	20	10.5
For face grooving	CAFR/L-3T12-*	12	10.4
	CAFR/L-4T16-*	16	10.5
	CAFR/L-5T20-*	20	10.5
	CAFR/L-6T20-*	25	10.5

Notice in "turning"

When turning, the insert is pushed by the directional cutting force feed. As a result of this condition the diameter of the workpiece may change. (see Fig. 1) In such cases, trial cutting is

essential to measure the actual diameter. For your reference, sample of compensated values are shown in Fig. 2.

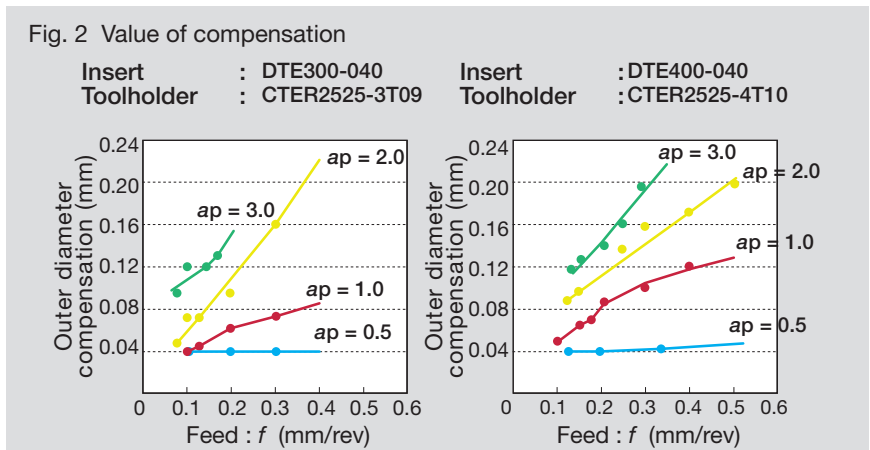
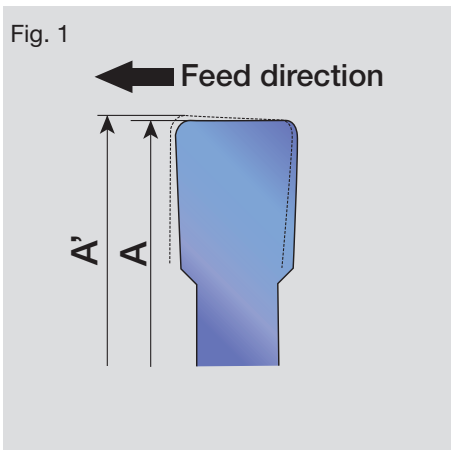

● **Guideline for ordering special inserts**
Specially designed inserts are available upon request.

Acceptable specification

- Specialized inserts must be manufactured from the main insert styles shown below.
- AH725, GH130 and TH10 grades are available.
- ※ Please contact Tungaloy for more details.

External grooving & turning		Internal grooving & turning	Profiling & undercutting	
DTE (Ground)	DGE (Ground)	DTI (Ground)	DTR (Ground)	DTIU (Ground)
				

● **Designation system for special inserts (sample)**

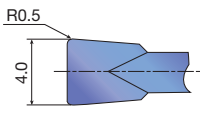
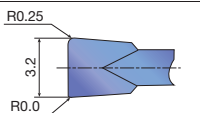
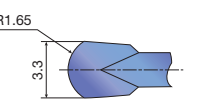
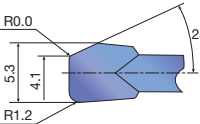
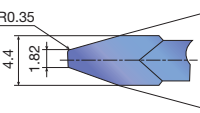
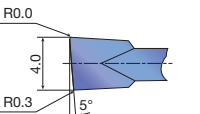

DTE	320	- 000R-025L	AH725
1 Main style of insert	2 Max. width of insert	3 Additional codes	4 Grade

● **Sample of shape**

Shape	Samples of designation	Note
	DTE400-050 GH130	Main style: DTE type Special corner radius
	DTE320-000R 025L AH725	Main style: DTE type Special corner radius, asymmetric type
	DTR330-165 TH10	Main style: DTR type Full radius type with special insert width
	DTE530-120R-25LA TH10	Main style: DTE type Special figure of groove, asymmetric type
	DTE440-035-29A TH10	Main style: DTE type Special figure of groove
	DTE400-030R-005RA TH10	Main style: DTE type Right handed insert with special angle and corner radius.

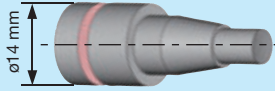
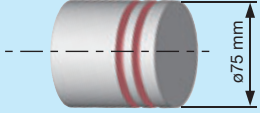
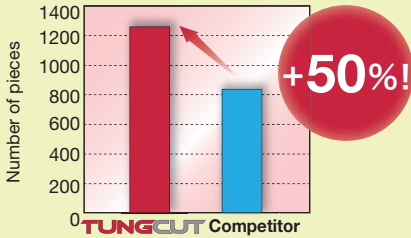
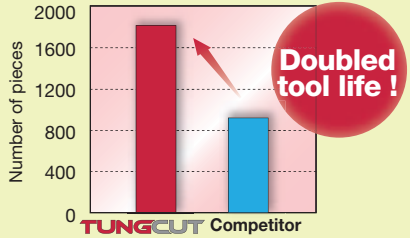
Practical examples

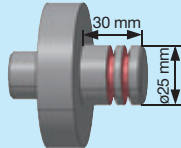
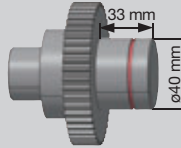
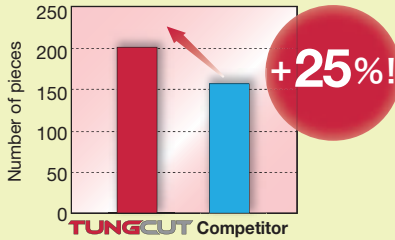
Workpiece type		Automotive parts	Machine parts
Toolholder		CTER1616-2T08	CTER2525-4T10
Insert		DGM2-020	DGM4-030
Grade		AH725	AH725
Workpiece material		SCr440 / 41Cr4	SCr440 / 41Cr4
		 P	 P
Cutting conditions	Grooving width: W (mm)	2	4
	Cutting speed: V_c (m/min)	94	150
	Feed: f (mm/rev)	0.08	0.10
	Machining	Parting off	Grooving
	Cutting edge depth (mm)	-	6
	Coolant	Water soluble	Water soluble
Results		 +50%!	 Doubled tool life!
		TungCut has higher wear resistance and achieves tool life improvements of 150%.	TungCut provides better chip control and doubles tool life.

Workpiece type		Machine parts	Gear
Toolholder		CTEL2020-3T09	CTER2525-2T08
Insert		DTE3-040	SGN200-020
Grade		T9125	BX360
Workpiece material		S53C / C53	SCM415H (58HRC) / 18CrMo4
		 P	 H
Cutting conditions	Grooving width: W (mm)	3	2
	Cutting speed: V_c (m/min)	200	120
	Feed: f (mm/rev)	0.2	0.05
	Machining	Grooving	Grooving
	Cutting edge depth (mm)	5	0.8
	Coolant	Water soluble	Water soluble
Results		 +25%!	 +50%!
		The excellent wear resistance of TungCut improves tool life by 25%, even when machining at high speed.	TungCut extends tool life by 1.5 times when hardened steel cutting. This is a result of the extremely stable CBN grade.

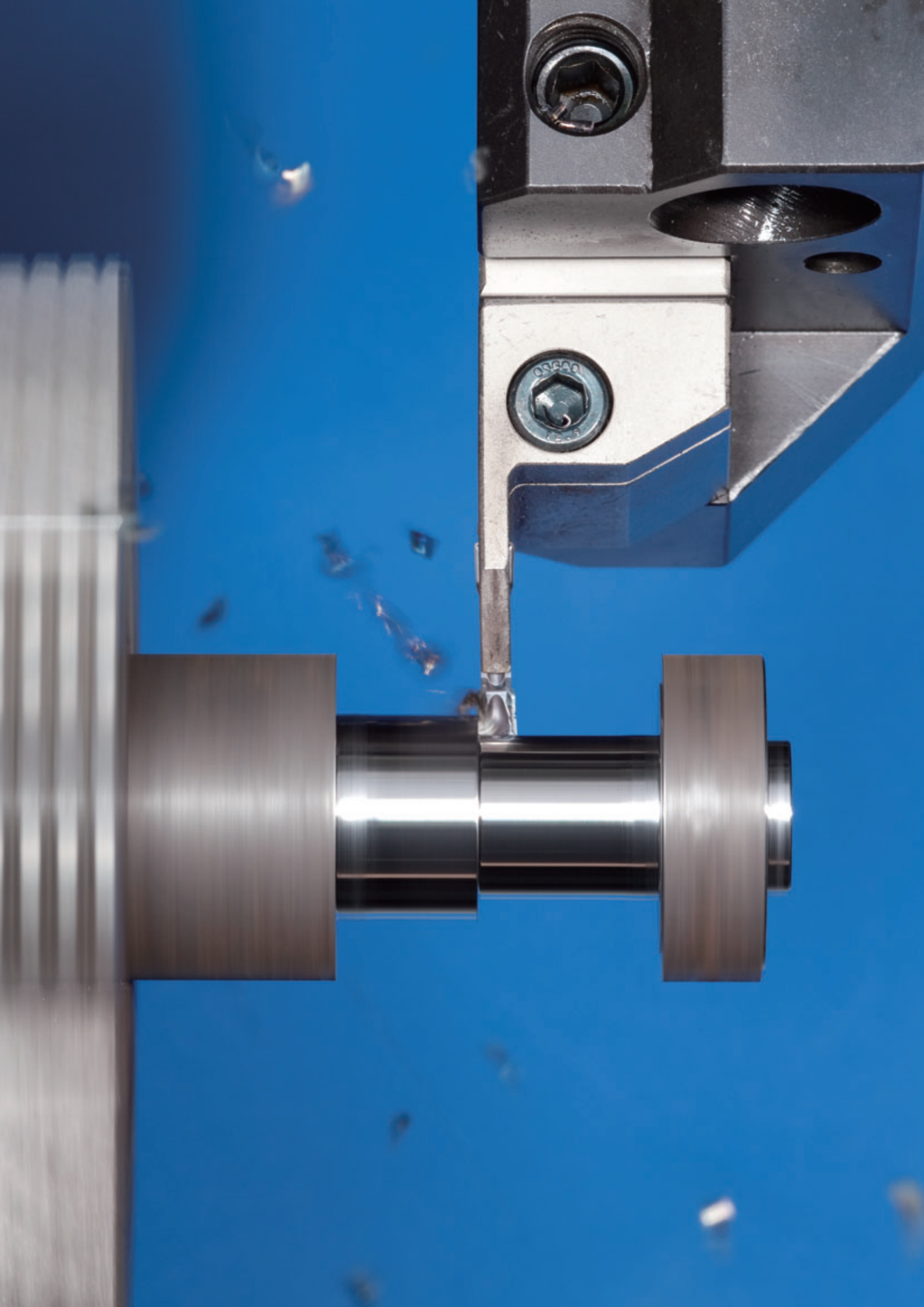

Tungaloy Corporation (Head office)

11-1 Yoshima-Kogyodanchi
Iwaki-city, Fukushima, 970-1144 Japan
Phone: +81-246-36-8501
Fax: +81-246-36-8542
www.tungaloy.co.jp

Tungaloy America, Inc.

3726 N Ventura Drive
Arlington Heights, IL 60004, U.S.A.
Phone: +1-888-554-8394
Fax: +1-888-554-8392
www.tungaloyamerica.com

Tungaloy Canada

432 Elgin St. Unit 3
Brantford, Ontario N3S 7P7, Canada
Phone: +1-519-758-5779
Fax: +1-519-758-5791
www.tungaloy.co.jp/ca

Tungaloy de Mexico S.A.

C Los Arellano 113,
Parque Industrial Siglo XXI
Aguascalientes, AGS, Mexico 20290
Phone: +52-449-929-5410
Fax: +52-449-929-5411
www.tungaloy.co.jp/mx

Tungaloy do Brasil Ltda.

Rua dos Sabias N.104
13280-000 Vinhedo, São Paulo, Brazil
Phone: +55-19-38262757
Fax: +55-19-38262757
www.tungaloy.com/br

Tungaloy Germany GmbH

An der Alten Ziegelei 1
D-40789 Monheim, Germany
Phone: +49-2173-90420-0
Fax: +49-2173-90420-19
www.tungaloy.de

Tungaloy France S.A.S.

ZA Courtaboeuf - Le Rio
1 rue de la Terre de feu
F-91952 Courtaboeuf Cedex, France
Phone: +33-1-6486-4300
Fax: +33-1-6907-7817
www.tungaloy.fr

Tungaloy Italia S.r.l.

Via E. Andolfato 10
I-20126 Milano, Italy
Phone: +39-02-252012-1
Fax: +39-02-252012-65
www.tungaloy.it

Tungaloy Czech s.r.o.

Turanka 115
CZ-627 00 Brno, Czech Republic
Phone: +420-532 123 391
Fax: +420-532 123 392
www.tungaloy.cz

Tungaloy Ibérica S.L.

C/Miquel Servet, 43B, Nau 7
Pol. Ind. Bufalvent
ES-08243 Manresa (BCN), Spain
Phone: +34 93 113 1360
Fax: +34 93 876 2798
www.tungaloy.es

Tungaloy Scandinavia AB

S:t Lars Väg 42A
SE-22270 Lund, Sweden
Phone: +46-462119200
Fax: +46-462119207
www.tungaloy.se

Tungaloy Rus, LLC

36-D Harkovsky Lane
308009 Belgorod, Russia
Phone: +7 4722 24 00 07
Fax: +7 4722 24 00 08
www.tungaloy.co.jp/ru

Tungaloy Polska Sp. z o.o.

ul. Genewska 24
03-963 Warszawa, Poland
Phone: +48-22-617-0890
Fax: +48-22-617-0890
www.tungaloy.co.jp/pl

Tungaloy U.K. Ltd

The Technology Centre,
Wolverhampton Science Park
Glaisher Drive, Wolverhampton
West Midlands WV10 9RU, UK
Phone: +44 121 4000 231
Fax: +44 121 270 9694
www.tungaloy.co.jp/uk
salesinfo@tungaloyuk.co.uk

Tungaloy Hungary Kft

Erzsébet királyné útja 125
H-1142 Budapest, Hungary
Phone: +36 1 781-6846
Fax: +36 1 781-6866
www.tungaloy.co.jp/hu
info@tungaloytools.hu

Tungaloy Turkey

Dudullu OSB 4. Cad No:4
34776 Umraniye Istanbul, TURKEY
Phone: +90 216 540 04 67
Fax: +90 216 540 04 87
www.tungaloy.com.tr
info@tungaloy.com.tr

Tungaloy Benelux b.v.

Tjalk 70
NL-2411 NZ Bodegraven, Netherlands
Phone: +31 172 630 420
Fax: +31 172 630 429
www.tungaloy-benelux.com

Tungaloy Croatia

Josipa Kozarca 4
10432 Bregana, Croatia
Phone: +385 1 3326 604
Fax: +385 1 3327 683
www.tungaloy.hr

Tungaloy Cutting Tool (Shanghai) Co.,Ltd.

Rm No 401 No.88 Zhabei
Jiangchang No.3 Rd
Shanghai 200436, China
Phone: +86-21-3632-1880
Fax: +86-21-3621-1918
www.tungaloy.co.jp/tcts

Tungaloy Cutting Tool (Thailand) Co.,Ltd.

TCIF Tower 4th Fl.
1858/5-7 Bangna-Trad Road
km.5 Bangna, Bangna, Bangkok 10260
Thailand
Phone: +66-2-751-5711
Fax: +66-2-751-5715
www.tungaloy.co.th

Tungaloy Singapore (Pte.), Ltd.

62 Ubi Road 1, #06-11 Oxley BizHub 2
Singapore 408734
Phone: +65-6391-1833
Fax: +65-6299-4557
www.tungaloy.co.jp/tspl

Tungaloy Vietnam

Unit 18, 4th Fl. Saigon Centre Building
65 Le Loi Blvd.
Dist 1, Ho Chi Minh City, Vietnam
Phone: +84-8-3827-0201
Fax: +84-8-3827-0203
www.tungaloy.co.jp/tspl

Tungaloy India Pvt. Ltd.

Indiabulls Finance Centre,
Unit # 902-A, 9th Floor,
Tower 1, Senapati Bapat Marg,
Elphinstone Road (West),
Mumbai -400013, India
Phone: +91-22-6124-8804
Fax: +91-22-6124-8899
www.tungaloy.co.jp/in

Tungaloy Korea Co., Ltd

#1312, Byucksan Digital Valley 5-cha
Beotkkot-ro 244, Geumcheon-gu
153-788 Seoul, Korea
Phone: +82-2-2621-6161
Fax: +82-2-6393-8952
www.tungaloy.co.jp/kr

Tungaloy Malaysia Sdn Bhd

50 K-2, Kelana Mall, Jalan SS6/14
Kelana Jaya, 47301
Petaling Jaya, Selangor Darul Ehsan
Malaysia
Phone: +603-7805-3222
Fax: +603-7804-8563
www.tungaloy.co.jp/my

Tungaloy Australia Pty Ltd

PO Box 2232, Rowville,
Victoria 3178, Australia
Phone: +61-3-9755-8147
Fax: +61-3-9755-6070
www.tungaloy.com.au

PT. Tungaloy Indonesia

Kompleks Grand Wisata Block AA-10 No.3-5
Cibitung
Bekasi 17510, Indonesia
Phone: +62-21-8261-5808
Fax: +62-21-8261-5809
www.tungaloy.co.jp/id



www.tungaloy.com

follow us at:
facebook.com/tungaloyjapan
twitter.com/tungaloyjapan

To see this product in action visit:

Tung-TV

www.youtube.com/tungaloycorporation

Distributed by:



DOWNLOAD
Dr. Carbide
Tungaloy



Available on the
App Store



GET IT ON
Google play



ISO 9001 Certified
QC00J0056
Tungaloy Corporation
18/10/1996
ISO 14001 Certified
EC97J1123
Tungaloy Group
Japan site and Asian
production site
26/11/1997